

MENLOTA

AMERICA'S LUXURY FIREPLACE

GAS DIRECT VENT FIREPLACE with Premium Fiber Log Set Combustion System

Model DXV-45 DT3

INSTALLATION & OPERATING INSTRUCTIONS

NATIONAL We recommend that our gas hearth products be installed and serviced by professionals who are certified in the U.S. by the National Fireplace Institute® (NFI) as NFI Gas Specialists.



www.nficertified.org

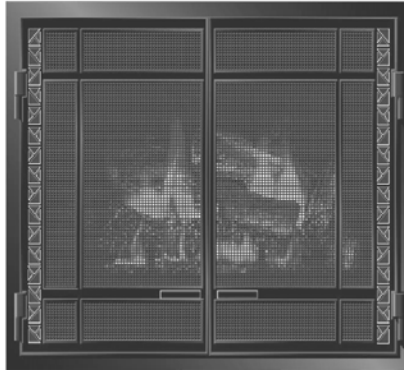

NO. DXV45-0812

WARNING

If you do not follow these instructions exactly, a fire or explosion may result causing property damage, personal injury or loss of life.

AVERTISSEMENT. Quiconque ne respecte pas à la lettre les instructions dans la présente notice risque de déclencher un incendie ou une explosion entraînant des dommages, des blessures ou la mort.

CAUTION: Keep gasoline and other liquids having flammable vapors away.

ATTENTION. Garder l'essence ou autres liquides produisant des vapeurs inflammables loin de l'appareil.

WHAT TO DO IF YOU SMELL GAS

- Do not try to light any appliance.
- Do not touch any electrical switch; do not use any phone in your building.
- Immediately call your gas supplier from a neighbor's phone. Follow the gas supplier's instructions.
- If you cannot reach your gas supplier, call the fire department.

QUE FAIRE SI VOUS SENTEZ UNE ODEUR DE GAZ :

- Ne pas tenter d'allumer d'appareil.
- Ne touchez à aucun interrupteur; ne pas vous servir des téléphones se trouvant dans le bâtiment.
- Appelez immédiatement votre fournisseur de gaz depuis un voisin. Suivez les instructions du fournisseur.
- Si vous ne pouvez rejoindre le fournisseur, appelez le service des incendies.

WARNING

Do NOT use this appliance if any part has been under water. Immediately call a qualified service technician to inspect the appliance and to replace any part of the control system and any gas control, which has been under water.

N'utilisez pas cet appareil s'il a été plongé dans l'eau, même partiellement. Faites inspecter l'appareil par un technicien qualifié et remplacez toute partie du système de contrôle et toute commande qui ont été plongés dans l'eau.

WARNING: Improper installation, adjustment, alteration, service or maintenance can cause injury or property damage. Refer to this manual. For assistance or additional information consult a qualified installer, service agency or the gas supplier.

AVERTISSEMENT : Une installation, un réglage, une modification, une réparation ou un entretien mal effectué peut causer des dommages matériels ou des blessures. Voir la notice de l'utilisateur qui accompagne l'appareil. Pour de l'aide ou des renseignements supplémentaires, consultez un installateur, un technicien agréé ou le fournisseur de gaz.

FOR YOUR SAFETY READ BEFORE LIGHTING

WARNING

Do not operate this appliance with the glass removed, cracked or broken. A licensed or qualified person should do replacement of glass.

Attention. Ne pas utiliser l'appareil si le panneau frontal en verre n'est pas en place, est craqué ou brisé. Confiez le remplacement du panneau à un technicien agréé.

This appliance must be installed in accordance with local codes, if any; if none, follow the National Fuel Gas Code, ANSI Z223.1, or Canadian Installation Codes, CAN/CGA-B149. Gas and Propane Installation Code, CSA B149.1

Installer l'appareil selon les codes ou règlements locaux, ou, en l'absence de tels règlements, selon les codes d'installation ANSI Z223.1, National Fuel Gas Code ou CAN/CGA-B149 en vigueur.

This appliance is only for use with the type(s) of gas indicated on the rating plate and may be installed in an aftermarket, permanently located, manufactured home (USA only) or mobile home, where not prohibited by local codes. See owner's manual for details.

Cet appareil doit être utilisé uniquement avec le type de gaz indiqué sur la plaque signalétique. Cet appareil peut être installé dans une maison préfabriquée ou mobile (É.-U. seulement) installée à demeure si les règlements locaux le permettent. Voir la notice de l'utilisateur pour plus de renseignements.

Caution: Label all wires prior to disconnection when servicing controls. Wiring errors can cause improper and dangerous operation.

In the Commonwealth of Massachusetts:

- Installation must be performed by a licensed plumber or gas fitter;
- A CO detector shall be installed in the room where the appliance is installed.

Attention. Au moment de l'entretien des commandes, étiquetez tous les fils avant de les débrancher. Des erreurs de câblage peuvent entraîner un fonctionnement inadéquat et dangereux.

CAUTION
THESE INSTRUCTIONS ARE TO REMAIN WITH THE HOMEOWNER.

DXV45 DT3 FEATURES - QUICK REFERENCE INFORMATION

EXTERNAL DIMENSIONS: 40-3/8" Wide X 39" High X 19-1/8" Deep

MINIMUM FRAMING DIMENSIONS: 41" WIDE x 38-1/8" HIGH X 20" DEEP

GLASS SIZE: NeoCeram Glass with non-reflective coating. Visible Glass measures 707.5 in². Actual Glass size is 840 in².

MANTEL ALLOWANCE: 8" Deep Mantel at 14" Above Top Convection Opening

VENT SYSTEM ALLOWANCE: Top Vent Only. 0" Vertical 24" max horizontal. 55 feet Vertical Maximum. 5" exhaust and 8" combustion air intake coaxial vent pipe required. 12' maximum horizontal run allowed with 4' minimum vertical starter section.

VENT DAMPER ADJUSTMENT AVAILABLE: There is one exhaust vent damper included in this unit and located in the top convection chamber at the center.

CONTROLS: IPI Electronic Ignition System with AC Primary Power and DC Backup Power. Accent light and Blowers operate on AC Power only.

BLOWER SYSTEM: 210 CFM Dual Blower System. 120VAC, 2Amps. Dedicated Hot Power only. No switches, Fan Speed Controls or Light Dimmers are allowed in same circuit.

Accent Light System: Accent Light System Included. Light can be turned on or off or dimmed using dimmer mounted behind lower grill.

BURNER SYSTEM: Dual 304 Stainless Steel Tubular burners.

BURNER AIR SHUTTER SYSTEMS: Externally controllable Rear Burner air shutter and Internal rotary Front Burner air shutter.

LOG SET: 10-piece, Premium Fiber Log Set with Real- Glow effects and Real ember bed.

REFRACTORY PANELS: High Detail Red Clinker Soldier Course Fiber Brick Panels included. Brick Panels required for operation.

NATURAL GAS INFORMATION: Factory equipped for Natural Gas. 4.5"WC Minimum inlet pressure required. For NG applications, Front Burner Orifice Size is #44 and the Rear Burner Orifice Size is #38.

LPG INFORMATION: An LP conversion kit is required to burn LPG in this appliance. Use either kit #AA-11-01257 or kit #HA-42-00225 to convert this appliance to burn LPG. 12"WC Minimum inlet pressure required. For the DXV45 DT3 LPG application, Front and Rear orifices are to be #53 (Rear) and 3/64" (Front). For higher altitude, adjustment to orifice size may be necessary.

INITIAL STARTUP ADVICE

PAINT CURING CYCLE RECOMMENDATION: It is recommended that you run this Fireplace on maximum flame height, for 3 cycles of 2 hours ON and 2 hours OFF, initially, to cure the paint. Some non-toxic smoking will be visible during the cure cycles. It is recommended that all windows be opened during the first 2-hour burn cycle to expel the visible smoke.

BLOWER BREAK-IN PERIOD: The integrated blowers in this Insert may exhibit some bearing noise and electrical static noise during the first few days of operation. This is normal during the break-in period. It is recommended that following the Paint Curing Cycle, the blowers be run at their maximum speed for two 3-hour periods. The burner flames must be on during these cycles. The blowers in a few fireplaces may take longer to break-in and may require additional operation time before all extraneous noise is eliminated. Please allow adequate operational time for the blowers to break-in before you contact your dealer for service.

Contents

FOR YOUR SAFETY READ BEFORE LIGHTING	1
DXV45 DT3 FEATURES - QUICK REFERENCE INFORMATION	2
CONTENTS	3
SPECIFICATIONS	4
CONGRATULATIONS!	5
LOCATING THE FIREPLACE AND GENERAL INFORMATION	6
HEATING PERFORMANCE	7
DXV-45 GAS DIRECT VENT FIREPLACE	8
INSTALLATION INSTRUCTIONS	9
GAS SUPPLY REQUIREMENTS	10
GAS PRESSURE REQUIREMENTS	11
EXTERIOR VENT LOCATIONS AND RESTRICTIONS	12
FLUE VENTING INSTRUCTIONS	13
5"/ 8"FLUE VENTING COMPONENTS FOR NG AND LPG	15
A-1 MINIMUM RISE THROUGH-THE-WALL VENTING FOR NG AND LPG	17
A-2 ELEVATED RISE THROUGH-THE-WALL VENTING FOR NG AND LPG	18
B - 1 VERTICAL THROUGH-THE-ROOF VENTING FOR NG AND LPG	19
MENDOTA DESIGNER FRONTS INSTALLATION INFORMATION	21
GLASS FRAME ASSEMBLY REPAIR AND REPLACEMENT	24
COMPLETED LOGS AND COAL BED ASSEMBLY EVALUATION	31
INSTALLATION CHECK OFF LIST	32
LIGHTING CHECK OFF LIST	32
BEFORE YOU BEGIN	33
"FIRST TIME" LIGHTING INSTRUCTIONS	34
THERMOSTAT OR REMOTE CONTROL OPERATION	35
BLOWER OPERATION AND WIRING	36
TROUBLESHOOTING MENDOTA GAS DXV FIREPLACE	37
CUSTOMER INFORMATION AND TROUBLE-SHOOTING	38
MAINTENANCE	39
WIRING SCHEMATICS	40
BLOWER SYSTEM WIRING SCHEMATIC NATURAL TO LP GAS CONVERSION INSTRUCTIONS	40
NATURAL TO LP GAS CONVERSION INSTRUCTIONS	41
INSTALLING THE LP PRESSURE REGULATOR	44
LP GAS PRESSURE REQUIREMENTS	45
REPLACEMENT PARTS	46
MENDOTA WARRANTY QUALIFICATION & SERVICE REFERENCE FORM	48

SPECIFICATIONS

MENDOTA, MODEL DXV-45

High Fire - Adjustable to - Low Fire

BTUH. (MODEL DXV-45)	NAT. GAS	45,000	7,500
BTUH. (MODEL DXV-45)	L.P. GAS	40,000	5,000

NOTE: LP CONVERSION KIT #HA-42-00225 OR AA-11-01257 MUST BE PURCHASED SEPARATELY FOR THE DXV-45 FIREPLACE TO BURN LPG.

MAIN ORIFICE: REAR BURNER #38 NAT. GAS-#53 L.P. GAS – FRONT BURNER #44 NAT. - #3/64 LP

OVERALL EFFICIENCY EXCEEDS D.O.E. EFFICIENCY REQUIREMENTS (A.F.U.E.) FOR DIRECT VENT WALL HEATERS

CO-AXIAL DIRECT VENT FLUE 5" INNER, 8" OUTER

TOTAL WEIGHT 205 POUNDS

SAFETY AGA CERTIFIED IPI PILOT SAFETY SYSTEM, ACTIVATED WITH SWITCH, THERMOSTAT OR REMOTE CONTROL.

GAS REQUIREMENTS SUPPLY PRESSURE: GAS INLET: 3/8" N.P.T.

NAT. GAS: 7" W.C. (5" W.C. MIN., 11" W.C. MAX.)

L.P. GAS: 12.0" W.C. (12" W.C. MIN., 14" W.C. MAX.)

ELECTRICAL REQUIREMENTS 120 VOLT ON LEFT OR RIGHT SIDE OF APPLIANCE. CONNECT TO ONLY ONE OF THE TWO SERVICE OUTLET BOXES INSTALLED IN THIS APPLIANCE. USE EITHER RIGHT SIDE OR LEFT SIDE SERVICE OUTLET BOX CONNECTION.

APPROVED VENT SYSTEMS: AMERIVENT, DURAVENT, SELKIRK METALBESTOS, SECURITY CHIMNEY

Certified under ANSI Z21.88-2005•CSA 2-33-2005 and CAN/CGA 2.17 M91. DXV-45 is also deemed in compliance with ANSI Z21.50•CSA 2.22 2000“Vented Gas Fireplace Heaters” not for use with solid fuel. Approved for bedroom installations and mobile homes. UL307B approved for "mobile homes, after first sale of home, not for recreational vehicles." “Gas-fired appliances for use at high altitudes.”

<p>HIGH ALTITUDE INSTALLATION INFORMATION: Prior to installing at altitudes higher than 7500, please contact the Mendota technical service department for specific venting requirements and venting restrictions.</p>
--

CONGRATULATIONS!

You are the owner of a world class, heat producing, gas, direct vent, sealed combustion fireplace.

This elegant, highly efficient Fireplace will be a constant source of comfort and fascination. It will be the focal point of beauty and interest in your home.

The Mendota Gas Fireplace is a true heating appliance incorporating the traditional aesthetics of fireplace fire viewing with the controllability and fuel efficiency of a home gas furnace. Of particular interest is the low fuel consumption and brilliant fire viewing afforded by the realistic, Deep Timber, wood fire-like combustion system.

Carefully read the following instructions prior to actual installation. Proper Mendota Gas Fireplace installation and operation will give you years of safe trouble free comfort and enjoyment.

If you have any questions regarding installation or operation of your Mendota Fireplace please contact your local dealer.

.....CAUTION.....

FOR YOUR SAFETY do not install or operate your Mendota Gas Fireplace without first reading and understanding this manual. Any installation or operational deviation from this manual voids the Mendota Gas Fireplace Warranty and may prove hazardous!

Due to high temperatures, the Fireplace should be located out of traffic and away from furniture and draperies. Children and adults should be alerted to the hazards of high surface temperature and should stay away to avoid burns or clothing ignition. Young children should be carefully supervised when they are in the same room as the Mendota Gas Fireplace.

Clothing or other flammable material should not be placed on or near the Fireplace.

The Mendota Gas Fireplace is a powerful, efficient heating unit. It has been designed as a major source of supplemental heat. As with any mechanical appliance there can be component shut downs. It is advisable to have an alternate heat supply.

Installation, repair and any adjustments to logs or burner must be done by a qualified service person. The Fireplace should be inspected before use and at least annually by a professional service person. More frequent cleaning may be required due to excessive lint from carpeting, bedding material, carbon build-up, etc. It is imperative that control compartments, burners and circulating air passageways of the appliance be kept clean. The burner and pilot flames and logs should be visually checked periodically.

DO NOT use this Fireplace if any part has been under water or exposed to moisture corrosion. Immediately call a qualified service technician to inspect the Fireplace and replace any part of the control system and any gas control, which has been under water. DO NOT use this fireplace if the burner does not light immediately. Turn unit off and call Mendota approved service person if there is any delay in burner light off.

It is Johnson Gas Appliance Company's policy that no responsibility is assumed by the Company or by any of its employees or representatives for any damages caused by an inoperable, inadequate, or unsafe condition which is the result, either directly or indirectly, of any improper operation, installation or servicing procedures.

Building Permit and Installation Inspection Approval Requirements

All installations of Mendota Fireplaces and Inserts must comply with all the requirements stated in this Installation and Operating Instructions Manual. The Dealer and/or installer must also obtain all required Building Permits and Inspection Approval from the local building inspection department or the local body having jurisdiction. In order to validate warranty coverage, Mendota may require facsimile copies of the Building Permit and Inspection Approval forms. Failure to provide adequate proof that the installation conforms to all local requirements and the requirements stated in the Installation and Operating Instructions Manual will void all applicable warranty.



LOCATING THE FIREPLACE AND GENERAL INFORMATION

Your Mendota Gas Fireplace has a state-of-the-art co-axial direct vent, sealed combustion system. This advanced, highly efficient system brings in outside air for combustion, has a separate exhaust vent and efficiently heats and re-circulates room air. The Mendota system maintains high air quality, maximizes efficiency and assures proper operation.

SAFETY AND STRUCTURAL CONCERNS:

The DXV Fireplace must be installed and serviced by a Mendota approved service person. Any adjustments to burner, pilot, logs or coal bed must be made by a Mendota approved service person. Pilot flame must be checked with voltmeter. Pilot flame must register a minimum of 250 on mill volt meter. If pilot goes out always wait five (5) minutes before relighting pilot. Always remove the glass door when lighting the pilot. The burner must light immediately & the flame must travel promptly and smoothly around "curve" and light entire burner. The flame must not "lift off" burner. All vent pipe sections must be "twist locked" and leak proof.

The Mendota Direct Vent Fireplace may be placed within inches of adjacent sidewalls. (See FIGURE 1 on pg. 8). The fireplace may be placed directly on concrete or wood flooring. If the appliance is to be installed on carpeting, vinyl or other combustible material other than wood flooring, the appliance shall be installed on a metal or wood panel extending the full width and depth of the appliance. Combustible mantels must be installed as per FIGURE 1 on pg. 4. Non-combustible (marble, brick, stone, etc.) mantels or mantels with steel protector plate on underside maybe installed at any desired height above upper grill.

NEVER BLOCK OFF UPPER OR LOWER GRILLS. ALWAYS USE MENDOTA GRILLS, MENDOTA APPROVED VENT SYSTEMS AND MENDOTA APPROVED VENT CAPS. SEE PAGEA 8-15 FOR SPECIFIC VENTING INFORMATION.

KEEP ELECTRONIC APPLIANCES AWAY: DUE TO THE HIGH TEMPERATURES IN THE VICINITY OF THIS FIREPLACE, MENDOTA RECOMMENDS THAT ALL ELECTRONIC APPLIANCES INCLUDING AUDIO/VIDEO APPLIANCES AND THEIR RECORDING MEDIA (ie. TV, VCR, DVD PLAYER, CD PLAYER, TUNERS, TELEPHONES, CASSETTE TAPES, VIDEO TAPES, CDs, DVD CDs) BE KEPT WELL AWAY FROM THIS FIREPLACE.

VENTING REQUIREMENTS:

Use only Mendota specified vents and vent caps when installing your fireplace. Closely follow venting locations, directions and requirements (see pages 10-17). Observe the restrictions relating to vent position on exterior of home (see pg. 10).

HEATING PERFORMANCE

Mendota Gas Built-in Fireplaces are true, high efficiency gas heaters. With its high heat output the Mendota Fireplace will heat a large area of your home if situated to maximize heat circulation. Air movement options for maximizing heat circulation which can be considered are through-the-wall grills or floor grills, the continuous operation of central heating furnace blowers, or ceiling fan. **The most efficient method for overall heat distribution is a ceiling fan.** The heat output of the Fireplace can be reduced down to 22,500 BTUH by slowly turning the Hi/Lo temperature knob on the gas valve counter clockwise from "Hi" to "Lo". Further reduction of heat output, down to 7,500 BTUH, can be achieved by turning off the rear burner using the switch provided behind the lower grill. The blower can also be turned down to reduce heat output.

AESTHETIC CONSIDERATIONS:

Burning or static fireplaces are a major aesthetic focus in any room. Locate your gas fireplace as you would a television set. The Mendota Hearth Gas Fireplace will be a continuing source of comfort and fascination. Corner installations will afford you the greatest potential for viewing in many rooms.

HEARTH PROTECTION REQUIREMENTS: A non-combustible hearth protector is required and must extend a minimum of 14" in front of the fireplace (see Figure 1 on pg. 4 for raised hearths). We suggest installing the Mendota Fireplace 6 to 12 inches above the floor by utilizing an elevated hearth.

CAUTION: If you intend to install either the Andover Door Front or the Prairie Door Front on this fireplace, make certain that the top surface of the hearth protector is flush with the bottom surface of the fireplace, no higher. Failure to follow this guideline will prevent proper mounting and function of these two Fronts. See Page 16 for specific details.

ELECTRICAL REQUIREMENTS:

A blower is standard on your Mendota Direct Vent Fireplace; A 120 volt electrical service must be supplied at the fireplace location at the time of installation. It must be electrically grounded in accordance with local codes or in their absence with current edition of the National Electric Code ANSI/NFPA 70. Power supply to blower must be continuous. DO NOT use switch or variable control in power supplied to fireplace. Connect this 120 VAC supply line to either the left side or right side. **WARNING: CONNECT 120 VAC TO ONLY ONE OF THE TWO OUTLETS INSTALLED IN THIS APPLIANCE. THE TWO OUTLETS ARE CONNECTED INTERNALLY AT THE FACTORY.**

The blower on this appliance is equipped with a three-prong plug for protection against shock hazard and should be plugged directly into the grounded three-prong receptacle provided with the fireplace. **Do not cut or remove the grounding prong from the plug.**

NOTE: The blower output can be adjusted with the rheostat. There will be delays in blower operation during "heat-up" (approx. ½ hr.) and extended blower operation during "cool-down" (approx. ½ hr.) of unit (see Blower Wiring Diagram pg. **Error! Bookmark not defined.**).

Thermostat wire should be run from desired thermostat location (or "on/off") switch to the fireplace's ON/OFF switch terminals (located behind lower grill) – see thermostat installation section (pg.27).

DXV-45 GAS DIRECT VENT FIREPLACE

SPECIFICATIONS & CLEARANCES

DIRECT VENT COAXIAL PIPE SIZE: 5" I.D. X 8" O.D.

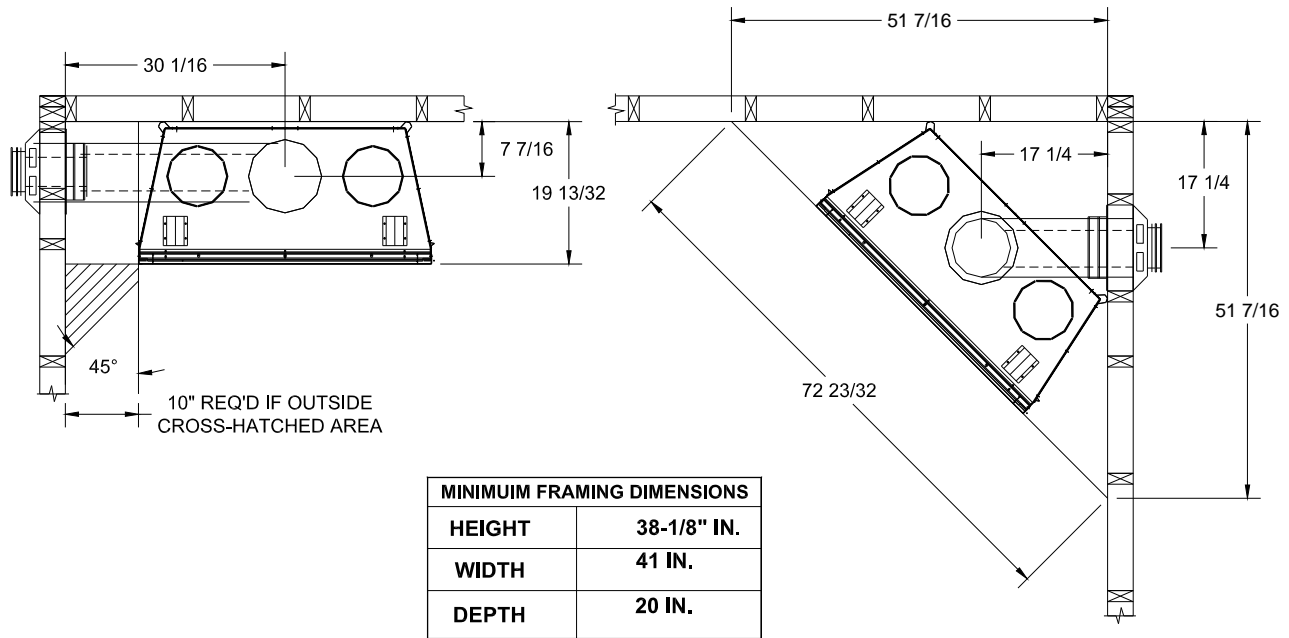

MINIMUM FRAMING DIMENSIONS	
HEIGHT	38-1/8" IN.
WIDTH	41 IN.
DEPTH	20 IN.

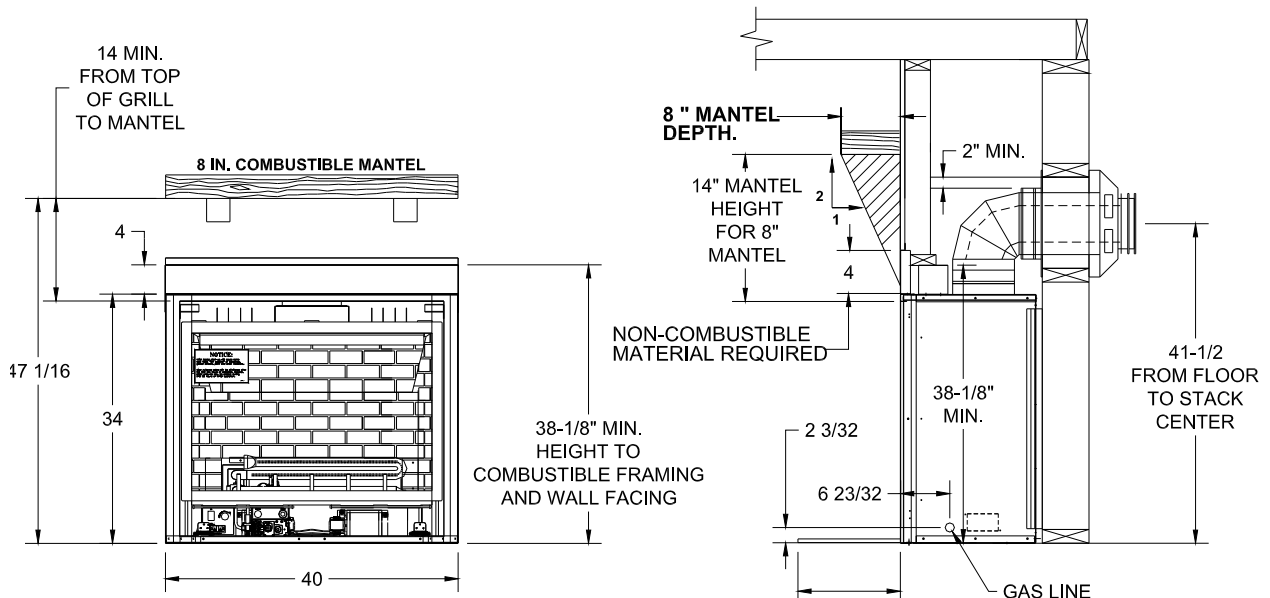

14" HEARTH PROTECTION [NOT REQUIRED IF FIREPLACE IS ELEVATED MIN. 6"]. FOR EVERY 1" THE UNIT IS ELEVATED, YOU MAY REDUCE HEARTH PROTECTION PAD DEPTH BY 2". SEE PAGE 17 FOR HEARTH PROTECTION REQUIREMENT WHEN INSTALLING ANDOVER OR PRAIRIE FRONTS.

FIGURE 1: Specifications & Clearances

HIGH ALTITUDE INSTALLATION INFORMATION: Prior to installing at altitudes higher than 7500, please contact the Mendota technical service department for specific venting requirements and venting restrictions.

INSTALLATION INSTRUCTIONS

CAUTION: Each installation must conform to all local, state and national codes. Refer to the national fuel gas code and local zoning and code authorities for details on installation requirements. The Mendota Fireplace must be vented to the outside in accordance with the latest edition of the National Fuel Gas Code. In the absence of local codes, the installation must conform to the most current edition of the National Fuel Gas Code ANSI Z223.1, also known as NFPA 54. **NOTE:** The Mendota DXV Fireplace is approved for mobile home and bedroom installations.

CAUTION: The Mendota DXV Fireplace may be installed in a manufactured (mobile) homes after the first sale of the home. Manufactured home (mobile home) installation must conform with the Manufactured Home Construction and Safety Standard, Title 24 CFR, Part 3280, or, when such a standard is not applicable, the Standard for Manufactured Home Installations, ANSI A225.1/NFPA 501A, or CSA Z240.4-Gas Equipped Mobile Housing. Consult your local building official. **Note:** For mobile home installations unit must be bolted to the floor and properly grounded.

1. After selection of the desired fireplace location, prepare the rough opening using framing dimensions on page 4. Prepare opening to allow for co-axial vent (see "Flue Venting Instructions" on pgs. 13-21).
2. Check to make certain all venting requirements and locations are being followed. (See pg 13 -21).
3. The Fireplace is designed to be installed into rough framing. The drywall will cover the adjustable nailing flanges on the Fireplace sides. Before sliding the Fireplace into the framed opening, adjust the nailing flanges to accommodate the thickness of the wall material. **NOTE:** FRAMING MATERIAL ABOVE FIREPLACE MUST MAINTAIN CORRECT CLEARANCES TO VENT PIPE.
4. Slide Fireplace into the rough framed opening. When finishing the unit, combustible materials may overlay nailing flanges and come in contact with the side edges of the black front surface, but may not overlay the 2" black surface. A 40-1/8" x 4" Top Screw Strip (part #HA-41-00015) is supplied with the fireplace and must be installed on the top of this fireplace. The Top Screw Strip provides a 4" clearance to combustible materials at the top of the fireplace. See Page 8 for specific details.
5. Combustible wall covering materials may only be installed down to the top flat edge of the Top Screw Strip. Noncombustible boards such as "Dura-Rock" or "wonder board" can be installed on top of the face of the Top Screw Strip and on top of the rest of the black face of the fireplace. Noncombustible material, such as marble or brick, can be installed over the 2" black surface up to the inside edges of black frame only if some Designer Fronts are to be installed. See Page 23 for specific details and exceptions. Rough framing can come no closer to unit than the stand-offs.
6. Level the Fireplace and secure into opening by nailing through the nailing flanges on cabinet side panels. Holes are provided in fireplace floor behind grill to lag screw fireplace to floor, if required. **NOTE:** A removable panel in the enclosure for future visual inspection of the flue connection is recommended
7. Have an electrician install a 120 Volt supply to the junction box on lower left side of the fireplace cabinet. Connect wires to the duplex outlet. This duplex outlet is removable from outside of cabinet for easy wiring. Make sure the outlet is properly grounded and that the installation conforms to all local and national wiring codes. See "Blower Operation" below, Blower Wiring Diagram and "Electrical Requirements".
8. Have gas supplier or qualified plumber install gas supply line to fireplace and connect to gas nipple. Be sure gas and plumbing instructions and all local and national codes are carefully followed. Carefully check for gas leaks and for proper gas pressure.

IMPORTANT: Any safety screen, guard, glass, grill, pressure relief cap, etc. removed for servicing a fireplace/room heater must be replaced prior to operating the fireplace/room heater.

BLOWER OPERATION

The Mendota DXV Fireplace is designed so the blower operates continually when main burner is on. The blower output can be regulated with the rheostat (included). **NOTE:** There will be a time delay in blower operation during "heat-up" (approx. 1/2 hour) and extended blower operation during "cool-down" of unit. (Approx. 1/2 hour).

OPERATION DURING POWER OUTAGES: This fireplace is designed to operate for a maximum 1-1/2 continuous hours during power outages. The blower will not operate, but natural convection can be improved by removing the upper Millennia grills, opening the Andover and Prairie Doors and opening the Wellington Screens.

GAS SUPPLY REQUIREMENTS

Correct gas pressure and proper gas supply line sizing is imperative to the successful performance of your Mendota gas fireplace. Be sure the gas supplier or plumber carefully checks for correct gas pressure and gas line sizing when installing the fireplace.

It is critical to carefully check for gas leaks when hooking up the fireplace -- check with soap & water solution.

Be sure to install "approved" flex gas line with brass-to-brass fittings to prevent gas leaks at connections.

Gas supply piping must include a drip leg to eliminate the possibility of contaminants entering the gas train. Adhere strictly to local and national codes for entire installation.

GAS SUPPLY LINE SIZING

The Mendota Gas Fireplace comes equipped with a 12" flexible connector kit including a manual shutoff ball valve. Gas supply piping must enter the Fireplace cabinet from the right side.

The included manual shut-off valve meets Federal Codes. If required by local codes, install an additional manual shutoff valve upstream of the fireplace's manual shutoff valve. The appliance and its individual shut-off valve must be disconnected from the gas supply piping system during any pressure testing of that system at test pressures in excess of ½ PSIG (3.5 kPa).

The appliance must be isolated from the gas supply piping system by closing its individual manual shut-off valve during any pressure testing of the gas supply piping system at test pressures equal to or less than 1/2 PSIG (3.5 kPa).

A proper gas line diameter must be selected to run from the supply regulator to the Fireplace. Refer to the following table for proper gas pipe diameters. Strictly adhere to the correct pipe sizes. If in doubt, use the next larger size.

PIPE LENGTH (FEET)	SCHEDULE 40 PIPE INSIDE DIA.		TUBING, TYPE L OUTSIDE DIA.	
	NAT.	L.P.	NAT.	L.P.
0-10	1/2" (1.3 cm)	3/8" (1.0 cm)	1/2" (1.3 cm)	3/8" (1.0 cm)
10-40	1/2" (1.3 cm)	1/2" (1.3 cm)	5/8" (1.6 cm)	1/2" (1.3 cm)
40-100	1/2" (1.3 cm)	1/2" (1.3 cm)	3/4" (2.0 cm)	1/2" (1.3 cm)
100-150	3/4" (2.0 cm)	1/2" (1.3 cm)	7/8" (2.3 cm)	5/8" (1.6 cm)
150-200	3/4" (2.0 cm)	1/2" (1.3 cm)	7/8" (2.3 cm)	3/4" (2.0 cm)

NOTE: Some areas allow copper tubing or galvanized pipe - check with local approval agencies and codes. NEVER use plastic pipe.

GAS PRESSURE CHECKING REQUIREMENTS

Inlet and manifold gas pressure checking taps are located on gas valve (see Figure 2 on Page 10). A qualified installer should use these fittings for setting the correct gas pressure during initial installation.

NOTE: DO NOT DAMAGE OR KINK THE FLEX CONNECTOR. CHECK FOR GAS LEAKS WITH SOAP AND WATER SOLUTION.

NOTE: 3/8" FLEX OR RIGID PIPING MAY BE USED TO CONNECT GAS SUPPLY TO UNIT DEPENDING ON STATE AND LOCAL CODES.

NOTE: BE SURE TO INSTALL FLEX GAS HOSE WITH BRASS-TO-BRASS FITTINGS TO PREVENT LEAKS AT CONNECTION.

NOTE: THE HARD PLUMBING FITTING PROVIDED IS TO BE USED WITH INSTALLATIONS REQUIRING HARD PLUMBING. IT MAY BE REMOVED IF THE FIREPLACE IS BEING INSTALLED WITH A FLEXIBLE CONNECTOR.

GAS PRESSURE REQUIREMENTS

A MAJOR CAUSE OF OPERATING PROBLEMS WITH GAS APPLIANCES CAN BE IMPROPER GAS PRESSURE!

Problems such as changes in flame color or flame height, pilot or burner outages, intermittent operation, changes in heat output, excessive burner noise, etc. are nearly always the result of changes in gas pressure or improper gas pressure at the time of the installation. The most important item to check during the installation and the first thing to check when problems occur is gas pressure!

Gas supplies normally enter a residence at 1/2 PSI (13" - 15" W.C.) (3. KPA). A regulator is then placed inside the residence, which drops this pressure to 7" W.C. (1.8 KPA) (Nat. Gas). This "inches to inches" regulator is of adequate capacity to service the gas appliances (such as dryer, furnace, etc.). If this regulator's capacity is not sufficient to add the Gas Fireplace, an additional "inches to inches" regulator must be installed for the Fireplace. EXCEPTION: Some codes allow 2-PSI (1.4KPA) supplies to enter the residence, in which case "pounds to inches" regulators are used.

The following table provides information on correct gas pressure requirements. Be sure your gas supplier or plumber carefully follows this table.

GAS PRESSURE REQUIREMENTS

	DESIRED INLET PRESSURE	MINIMUM INLET PRESSURE	MAXIMUM INLET PRESSURE	MANIFOLD OUTLET PRESSURE	AIR SHUTTER POSITION*
NATURAL GAS	7.0" W.C. (1.75 kPa)	5.0" W.C. (1.12 kPa)	11" W.C. (2.61 kPa)	3.5" W.C. (0.87 kPa)	1/16 - 3/16 " OPEN
L.P. GAS	12.0" W.C. (3.00 kPa)	11" W.C. (2.75 kPa)	13.0" W.C. (3.24 kPa)	10.0" W.C. (2.5 kPa)	1/4" OPEN-MIN.

TURN GAS VALVE KNOB TO "HIGH" POSITION. GAS PRESSURES MAY VARY PLUS OR MINUS 5%.

NOTE: For High Altitude (Above 5,000 Feet) Some Variations In Air Shutter Settings May Be Required.

Manifold pressure must be taken at the Output Pressure tap and inlet pressure at the Inlet Pressure tap **with the burner operating** by a qualified installer (see Figure 2: Gas Pressure Test Port).

Figure 2: Gas Pressure Test Ports

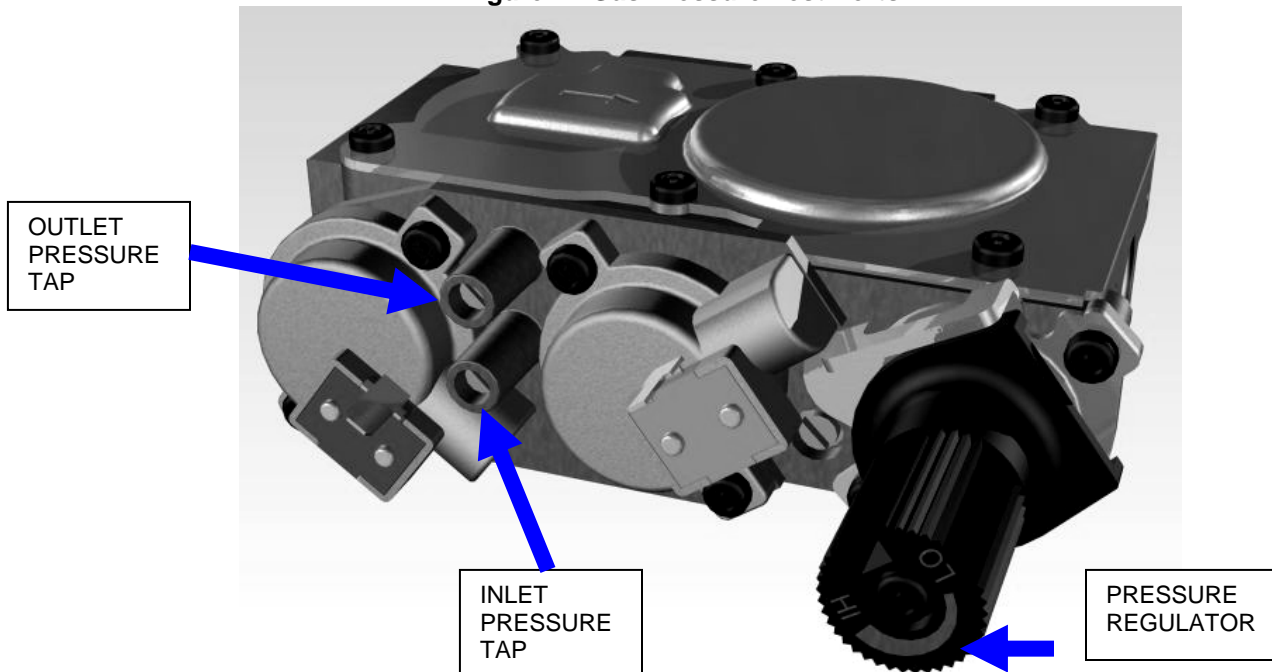

EXTERIOR VENT LOCATIONS AND RESTRICTIONS

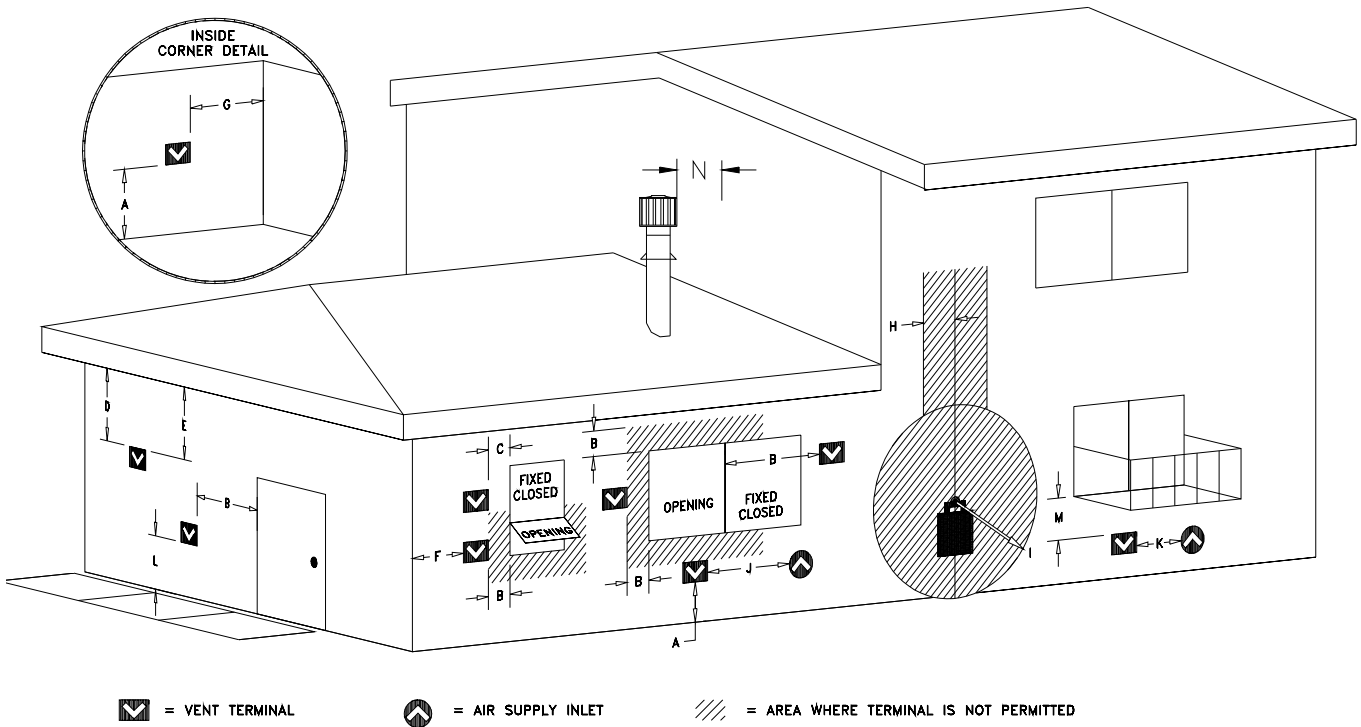

Figure 3: Exterior Vent Locations

NOTE: ALL MEASUREMENTS TO BE TAKEN FROM CENTER LINE OF VENT CAP

✓ - Vent Terminal △ - Air Supply Inlet ≡ - Area where terminal is not permitted

- A = Clearance above grade, veranda, porch, deck, or balcony (*12 inches (30 cm) minimum). Vinyl surfaces require 24" min.
- B = Clearance to window or door that may be opened (*12 inches (30 cm) minimum).
- C = Clearance to permanently closed window (minimum 12 inches (30 cm) recommended to prevent condensation on window)
- D = Vertical clearance to ventilated soffit located above the terminal from the center-line of the terminal (12 inches (30 cm) minimum) Vinyl surfaces require 24" min.
- E = Clearance to unventilated soffit (18 inches (46 cm) minimum) Vinyl surfaces require 24" min.
- F = Clearance to outside corner - 6 inches (15 cm).
- G = Clearance to inside corner - 12 inches (30 cm). Vinyl surfaces require 24" min.

- H = *Not to be installed above a meter/regulator assembly within 3 feet (90 cm) horizontally from the center-line of the regulator
- I = Clearance to service regulator vent outlet (*6 feet (1.8m) minimum)
- J = Clearance to non-mechanical air supply inlet to building or the combustion air inlet to any other appliance. *12 inches (30 cm) minimum.
- K = Clearance to a mechanical air supply inlet (*6 feet (1.8 m) minimum)
- L = † Clearance above paved side-walk or a paved driveway located on public property (*7 feet (2.1 m) minimum)
- M = Clearance under veranda, porch, deck, or balcony (*18 inches (30 cm) minimum ‡)
- N = Minimum 24" horizontal clearance to any surface, such as an exterior surface, for vertical terminations.

† A vent shall not terminate directly above a sidewalk or paved driveway, which is located between two single-family dwellings and serves both dwellings.
 ‡ Only permitted if veranda, porch, deck, or balcony is fully open on a minimum of two sides beneath the floor.
 * As specified in CGA B1:19 Installation Codes (1991). **Note:** Local codes or regulations may require different clearances.

FLUE VENTING INSTRUCTIONS

The Mendota Fireplace must be vented using DuraVent or Amerivent or Security venting system. All warranties will be voided and serious fire, health or other safety hazards may result from any of the following actions: Installation by unauthorized personnel; Installation of any damaged component; unauthorized modification of vent system; installation of any components not manufactured or approved by security chimney Simpson DuraVent, Amerivent and Mendota; failure to meet all clearance requirements; failure to properly twist-lock all components.

Consult local building codes before beginning the installation.

HIGH ALTITUDE INSTALLATION INFORMATION: Prior to installing at altitudes higher than 7500, please contact the Mendota technical service department for specific venting requirements and venting restrictions.

WARNING

Always maintain required clearances (air spaces) to combustibles to prevent a fire hazard. Do not fill air spaces with insulation. Check installation instructions for minimum clearance requirements between the outer walls of the vent pipe and nearby combustible surfaces. Be sure to check the vent termination clearance requirements from decks, windows, soffits, gas regulators, air supply inlets, and public walkways, as specified in these installation instructions and local building codes. **SAFETY PRECAUTIONS FOR THE INSTALLER:** 1) Wear gloves and safety glasses for protection; 2) Exercise extreme caution when using ladders or on roof tops; and 3) Be aware of electrical wiring locations in walls and ceilings.

The gas appliance and vent system must be vented directly to the outside of the building, and never attached to a chimney serving separate solid fuel or gas burner appliance. Each direct vent gas appliance must have its own separate vent system. Common vent systems are prohibited.

To assure proper venting performance of the high-performance Mendota Direct Vent Fireplaces and Stoves, it is critical that the DuraVent GS vent pipe sections are sealed tightly and leak-proof. This means that all pipe sections must be carefully rotated into the fully "twist-locked" position (Dura Vent only).

WE STRONGLY RECOMMEND THAT FIXED LENGTH PIPE SECTIONS BE USED IN PLACE OF TELESCOPING SECTIONS WHENEVER POSSIBLE

Note: When using Dura-vent DV pipe you must use a silicate stove masonry sealant [Millpak Sealant #65-06-00909] on all inner pipe joints. On the exterior (air intake) pipe joints, high temperature foil tape may be used instead of the masonry sealant. Contact your dealer to obtain this sealant material.

DO NOT SEPARATE TELESCOPING SECTIONS. THEY MUST BE USED AS COMPLETE ASSEMBLIES.

COMPONENT "TWIST-LOCK" CONNECTION PROCEDURE

DuraVent, Amerivent and Security brand pipe and fittings are designed with special twist-lock connections. Twist-lock procedure is as follows: four (4) indentations, located on the female ends of pipes and fittings are designed to slide straight in to the male ends of the adjacent pipes and fittings, by orienting the four pipe identifications so that they match and slide into the four entry slots on the male ends (FIGURE 4).

FIGURE 4: Twist-Lock Piping

Push the pipe sections completely together then twist-lock one section clockwise, approximately 1/4 turn until the two sections are fully locked. The female locking lugs will not be visible from the outside on the black pipe or fittings.

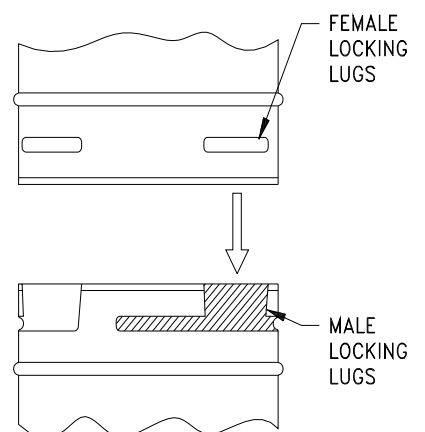

FLUE VENTING REQUIREMENTS FOR NG AND LPG

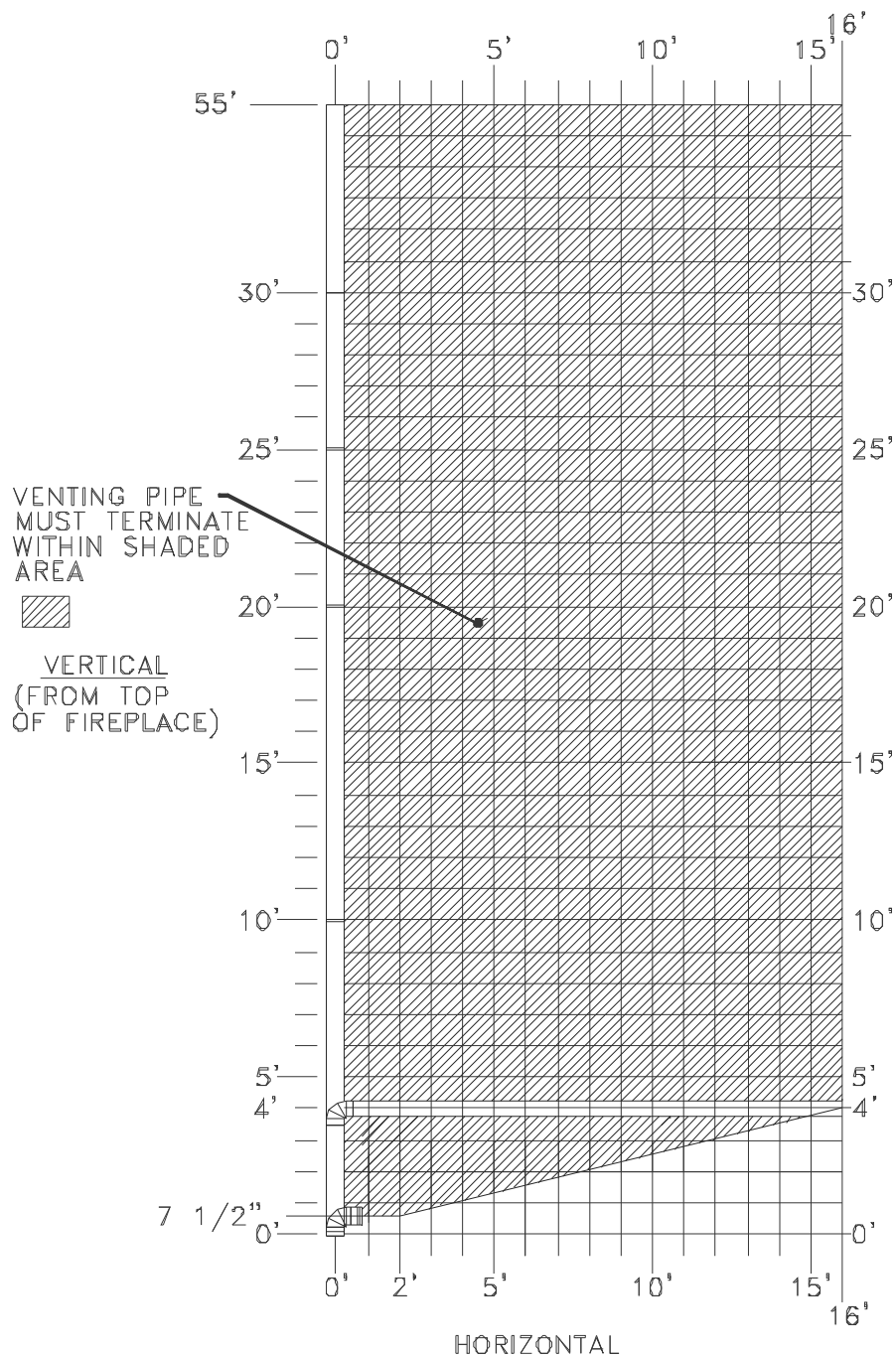

NOTE: IF A 90° ELBOW IS CONNECTED DIRECTLY TO THE FLUE OULET, THE MAXIMUM HORIZONTAL DISTANCE FROM THE FLUE OULET CENTERLINE TO THE OUTSIDE WALL IS 24".

A maximum of three (3) 90° elbows are allowed per installation.

Each 90° elbow USED, after the first 90° elbow, reduces the maximum horizontal distance by 3'. Each 45° elbow USED, after the first 90° elbow, reduces the maximum horizontal distance by 1-1/2'.

HIGH ALTITUDE INSTALLATION INFORMATION: Prior to installing at altitudes higher than 7500, please contact the Mendota technical service department for specific venting requirements and venting restrictions.

5" / 8" FLUE VENTING COMPONENTS FOR NG AND LPG

ITEM #	PART #	DESCRIPTION
1	45-01-00222	12" VENT STACK 5" / 8"
1	45-01-00223	24" VENT STACK 5" / 8"
1	45-01-00224	36" VENT STACK 5" / 8"
1	45-01-00225	48" VENT STACK 5" / 8"
2	45-01-00228	90° GALVANIZED ELBOW 5" / 8"
3	45-01-00227	45° GALVANIZED ELBOW 5" / 8"
4	45-01-00229	ADJUST. WALL THIMBLE 5" / 8"
5	45-01-00226	11 - 14" ADJUSTABLE PIPE 5" / 8"
9	45-01-00239	ATTIC INSULATION SHIELD 12" 5"/8"
10	45-01-00236	ROOF FLASHING (0/12 TO 6/12) 5" / 8"
10	45-01-00237	ROOF FLASHING (7/12 TO 12/12) 5"/8"
11	45-01-00238	STORM COLLAR 5" / 8"
12	45-01-00230	VERTICAL VENT CAP 5" / 8"
13	45-01-00234	SUPPORT BAND 5" / 8"
14	45-01-00231	HORIZONTAL VENT CAP 5" / 8"
15	45-01-00235	FIRESTOP SPACER 5" / 8"
16	45-01-00221	6" VENT STACK GALV. 5" / 8"
17	AA-11-00458	HEAT SHIELD (FOR VINYL, WOOD & COMBUSTIBLE SIDING)

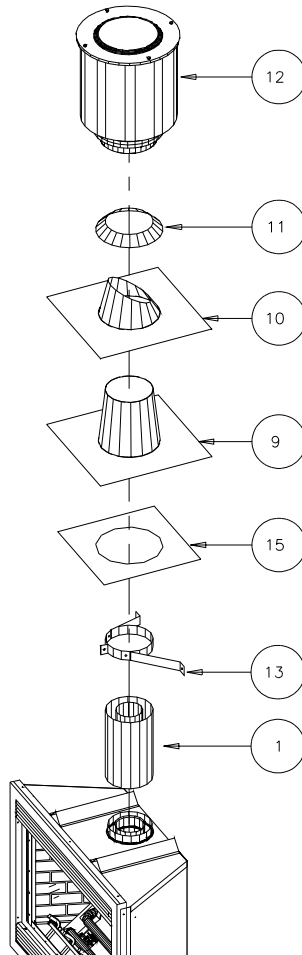

Adjustable– telescoping – pipe sections must be sealed using 1000° MILLPAK SILICATE STOVE MASONRY SEALANT (part #65-06-00909).

ALWAYS USE HEAT SHIELD WHEN WALL COVERING IS MADE OF VINYL, WOOD OR COMBUSTIBLE MATERIALS.

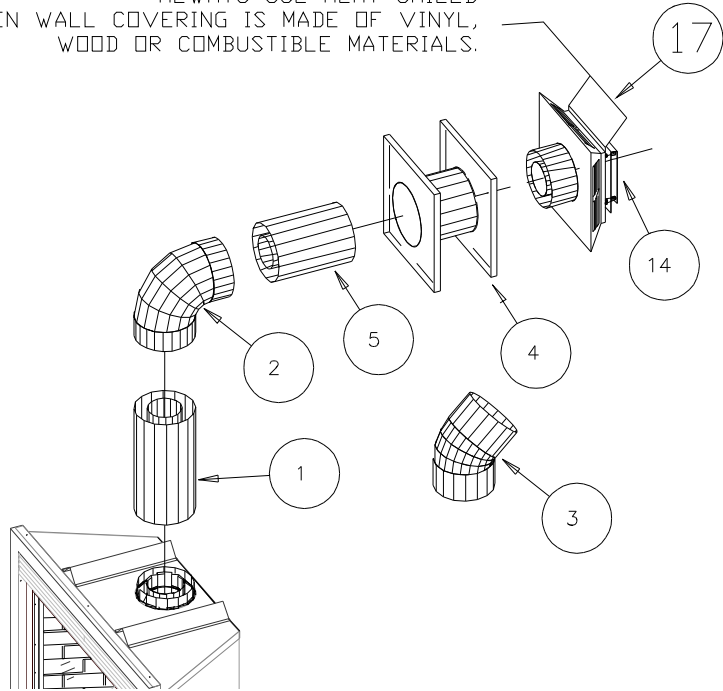

HIGH ALTITUDE INSTALLATION INFORMATION: Prior to installing at altitudes higher than 7500, please contact the Mendota technical service department for specific venting requirements and venting restrictions.

A-1 MINIMUM RISE THROUGH-THE-WALL VENTING FOR NG AND LPG

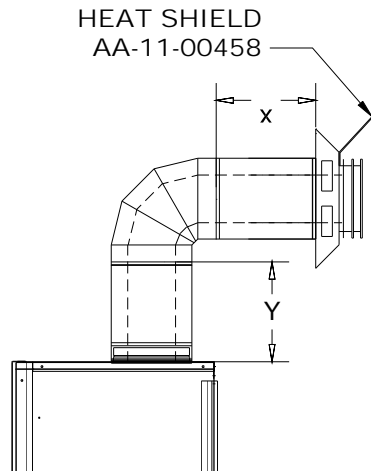

HEAT SHIELD #AA-11-00458

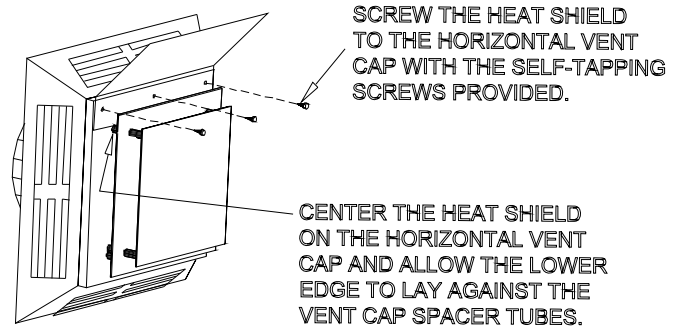

WARNING: ALWAYS USE HEAT SHIELD (#AA-11-00458) WHEN EXTERIOR WALL COVERING IS MADE OF VINYL, WOOD OR OTHER COMBUSTIBLE MATERIALS. HEAT SHIELD (#AA-11-00458) IS INCLUDED WITH THE DXV45 FIREPLACE.

IMPORTANT: REFER TO DRAWINGS ON PAGE 12-14 WHILE FOLLOWING THESE INSTRUCTIONS.

The horizontal distance from flue outlet center to outside wall must not exceed 24" if a 90° elbow is connected directly to flue outlet. ALWAYS MAINTAIN 1" CLEARANCES FROM VENT PIPE TO COMBUSTIBLES, 2" ABOVE PIPE ON HORIZONTAL RUNS. Use "fixed" pipe sections in place of adjustable pipe sections wherever possible. If adjustable pipe sections must be used, 1000° Millpak sealant (#65-06-00909) must be used on the inner pipe joints (DuraVent Only). Do not fill air spaces within the required clearance distances (1" around vertical pipe sections and 2" above horizontal pipes and fittings) with insulation or other material.

Position fireplace in desired location. See pg.12 for guidelines on proper vent cap placement on the exterior of home. Check to determine if wall studs are in the way when venting system is attached. If this is the case, you may want to adjust the fireplace location.

Measure from the top of the fireplace up minimum 7 1/2" to centerline of 90° elbow. (pg. 8) and mark wall directly at the center of where the vent pipe will penetrate the wall.

Cut and frame a 10-3/4" x 10-3/4" opening in the outside wall. The hole must be positioned so the vent system will run level or have a 1/4" rise AND be perpendicular to the wall. The height of the opening must be located to meet all local and national building codes and not allow the termination to be easily blocked or obstructed. If wall being penetrated is non-combustible material, i.e. masonry block, brick, etc., an 8 1/2" diameter hole is acceptable. A Wall Thimble (#45-01-00229) must be used when penetrating a combustible wall.

Make sure that all component connections are in their fully twist-locked position and are leak-proof. Make sure that 1000° Millpak sealant (#65-06-00909) is used on the inner pipe joints of all pipe sections (Dura Vent only).

***NOTE: DO NOT SEPARATE TELESCOPING SECTIONS. USE AS COMPLETE ASSEMBLIES.**

The length of the horizontal piece that fits through the wall will be determined by the thickness of the wall. When installed, the end of the horizontal piece must be flush with the exterior wall of the home. There MUST be a minimum of 1" air space clearance to combustibles from all vent pieces (2" above horizontal runs).

From the exterior of the home, slide the horizontal vent cap over the end of the horizontal pipe and tightly secure the cap to the wall with screws. Seal with a high quality caulking.

NOTE: The Horizontal Vent Cap should not be recessed into the wall or siding.

A-2 ELEVATED RISE THROUGH-THE-WALL VENTING FOR NG AND LPG

The minimum vertical rise from top of fireplace is 48 in. when used with the maximum horizontal run of 16 ft. For other venting configurations within these maximum limits see pg. 14.

NOTE: All horizontal runs of vent pipes must have a ¼" rise for every 1' of run toward the termination. Never allow the vent to run downward. This will cause high temperatures and the possibility of a fire.

USING OFFSETS AND RETURNS: A single 90° vertical-to-horizontal elbow is already calculated into the allowable maximum 16' horizontal run. Each additional 90° elbow reduces the maximum horizontal distance by 3'. A maximum of two 90° or four 45° elbows, in addition to the first 90° elbow, can be used (total equivalent of three (3) 90° elbows in entire vent system. 45° elbows reduce the maximum horizontal distance by 1½'.

SUPPORT: Horizontal runs of pipe will require one vent support for every 3 ft. of pipe.

CAUTION: Be sure to maintain 1" air space clearances to any combustibles around all pipe sections that are vertical. Be sure to maintain 1" air space clearances to any combustibles on the sides and below all horizontal pipe sections and elbows and 2" from the top of all horizontal pipes and fittings.

IMPORTANT: REFER TO DRAWINGS ON PAGE 14 & 15 WHILE FOLLOWING THESE INSTRUCTIONS.

Position fireplace in desired location. See pg. **Error! Bookmark not defined.** For guidelines on proper vent cap placement on exterior of home. Check to determine if wall studs are in the way when vent system is attached. If this is the case you may need to adjust the fireplace location.

Locate position where vent pipe will pass through any ceilings and will penetrate the outside wall. Since vent pipe sections "overlap" we suggest pre-assembling and measuring the total vent pipe run so you can more accurately locate the point where the vent pipe will penetrate the outside wall. Be sure all vent components are properly twist locked and leak-proof. Be sure 1000° silicate sealant (Millpak #65-06-00909) is used in the inner joints of all pipe sections (Dura Vent only).

*NOTE: DO NOT SEPARATE TELESCOPING SECTIONS USE AS COMPLETE ASSEMBLIES.

Cut and frame a 10-3/4" x 10-3/4" opening in the outside wall and in any ceiling openings. The outside wall hole must be positioned so the vent system will have a ¼" rise per foot of run AND be perpendicular to the wall. The height of the opening must be located to meet all local and national building codes and not allow the termination to be easily blocked or obstructed. A ceiling fire stop spacer is required at any floor (ceiling) opening.

Connect a 90° elbow to the fireplace adapter on top of fireplace vent outlet.

Always use a Wall Thimble (#45-01-00229) when penetrating a combustible wall.

The horizontal pipe must end flush with the exterior wall of the home. Horizontal pipe will require a proper support (part #45-01-00234) every 3 ft. of vent pipe. THERE MUST BE A MINIMUM OF 1" CLEARANCE TO COMBUSTIBLES FROM ALL VENT PIECES (2" above horizontal runs). From the exterior of the home, slide the horizontal vent cap over the end of the horizontal pipe and tightly secure the vent cap to the wall with screws. Seal with high quality caulking.

NOTE: Venting terminal should not be recessed into the wall or siding.

B - 1 VERTICAL THROUGH-THE-ROOF VENTING FOR NG AND LPG

The maximum vertical run of vent pipe is 36 ft. from the top of the fireplace. The fireplace will support a run of a maximum of 36 ft. Maintain 1" air space clearances on all sides of vents (2" above horizontal vents).

IMPORTANT: REFER TO DRAWING ON PAGE 10 & 11 WHILE FOLLOWING THESE INSTRUCTIONS.

Place the fireplace in its desired location. Drop a plumb bob from the ceiling to the center position of the fireplace flue exit. Mark the location where the vent will penetrate the ceiling. Drill a small hole at this point. Next, drop a plumb bob from the roof to the hole previously drilled in the ceiling. Mark and drill the spot where the vent will penetrate the roof. Determine if ceiling joists, roof rafters or other framing will obstruct the venting system. You may need to relocate the fireplace or need to offset, to avoid cutting load bearing members.

Cut and frame a 10-3/4" x 10-3/4" opening in the ceiling centered on the hole drilled in No. 1.

To determine the length of the vent pipe required, measure the distance from the fireplace flue outlet to the ceiling, the ceiling thickness, and the vertical rise in the attic or second story and allow sufficient vent height above roofline. For two story installations, fire stops are required at each floor level. If an offset is needed in the attic, additional pipe and elbows will be required.

Assemble the desired lengths of vent pipe and elbows to reach from the fireplace flue outlet. Ensure that all pipe and elbow connections are in their fully twist-lock position and are leak-proof. Maintain 1" airspace clearances to combustibles (2" above horizontal runs). Be sure 1000° silicate sealant (Millpak #65-06-00909) is used on the inner pipe joints of all pipe sections (DuraVent Only).

If an offset is necessary, it is important to support the vent pipe every 3 ft. to avoid excessive stress on the elbows and possible separation. Wall straps (#45-01-00231) are available for this purpose.

Whenever possible, use 45° elbows instead of 90° elbows. The 45° elbow offers less restriction to the flow of flue gases and intake air. If a 90° elbow is necessary there must be a minimum of a one-foot pipe section rise after the 90° elbow to the vent cap or to the next offset. A maximum of three (3) 90° elbows are allowed per installation.

Each 90° elbow, after the first 90° elbow, reduces the maximum horizontal distance by 3'. Each 45° elbow, after the first equivalent 90° elbow, reduces the maximum horizontal distance by 1-1/2'.

Cut a 12" x 12" opening in the roof, centered in the small drilled hole placed in the roof in No. 1. The opening should be a sufficient size to meet all clearance requirements. Continue to assemble lengths of pipe and elbows necessary to reach up through the roofline. Galvanized pipe and elbows may be utilized in the attic, as well as above the roofline. The galvanized finish is desirable above the roofline due to its higher corrosive resistance.

Slip the flashing over the pipe sections protruding through the roof. Secure the base of the flashing to the roof with roofing nails and seal flashing to roof. Ensure the roofing material overlaps the top edge of the flashing. Verify you have at least the minimum clearance to combustibles at the roofline.

Continue to add pipe sections until the pipe and the vent cap meet the minimum building code requirements, as outlined in No. 8 on the following page.

For multi-story vertical installation, a ceiling fire stop is required at the second floor and any subsequent floors. The opening should be framed to 12" x 12" inside dimensions as described in step No. 5.

Any occupied areas above the first floor, including closets and storage spaces, which the vertical vent passes through, must be enclosed. The enclosure may be framed and sheetrocked with standard construction materials, however, be sure to maintain minimum allowable clearances between the outside of the vent pipe and the combustible surfaces of the enclosure.

Height "*H" of top of vent cap can be determined as follows:

ROOF PITCH	"H" DIMENSION	
	FEET	METERS
FLAT to 6/12	2	.6
7/12 to 9/12	2	.6
10/12 to 12/12	4	1.2
13/12 to 16/12	6	1.8
17/12 to 21/12	8	2.4

Complete installation with storm collar and vent cap.

HIGH ALTITUDE INSTALLATION INFORMATION: Prior to installing at altitudes higher than 7500, please contact the Mendota technical service department for specific venting requirements and venting restrictions.

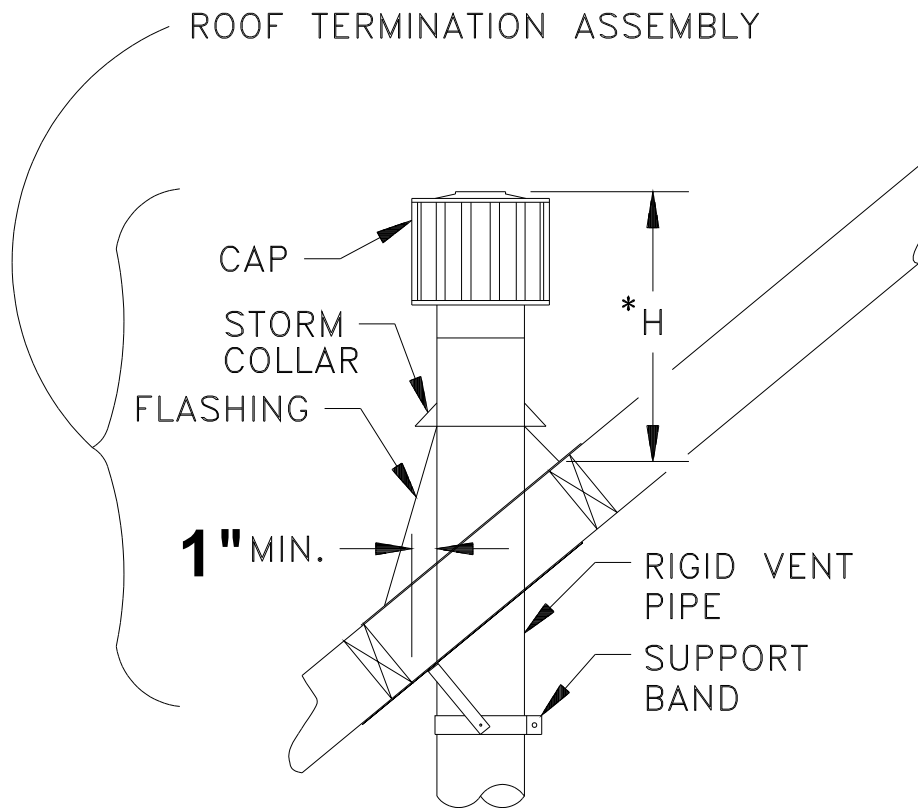

MENDOTA DESIGNER FRONTS INSTALLATION INFORMATION

The following Designer Fronts are available for the DXV-45 Fireplace:

1. Andover Arched Door Kit with Firescreen with optional Overlays as listed below:
2. Black Andover Overlay
3. Pewter Andover Overlay
4. Antique Copper Andover Overlay
5. Gold Andover Overlay
6. Prairie Rectangular Door Kit with Firescreen with optional Overlays as listed below:
7. Black Prairie Overlay
8. Pewter Prairie Overlay
9. Antique Copper Prairie Overlay
10. Gold Prairie Overlay
11. Black or Gold Victoria Filigree
12. Black or Gold Tuscany Filigree
13. Millennia Flat Grills in four optional color schemes as listed below:
14. Black Millennia Flat Grills
15. Full Brass Millennia Flat Grills
16. Classic Black and Brass Millennia Flat Grills
17. Classic Black and Bright Silver Millennia Flat Grills

Information specific to the installation of the Andover and Prairie Fronts

The Andover Door and Prairie Door Fronts are designed to be “Full-Face” trim kits. These two Fronts cover an area equivalent to that shown in the diagram below. Any material that protrudes into this area on the sides, top or bottom edges can only be flush with the front surface of the fireplace faceplate.

If planning to install either the Andover Door or the Prairie Door Front, **DO NOT COVER THE FACEPLATE OF THE FIREPLACE WITH ANY MATERIALS.** Furthermore, any drywall or wall covering material that is adjacent to the sides, top or bottom of the Fireplace’s faceplate may not protrude out past the front surface of the Fireplace Faceplate’s front surface.

The Andover and Prairie Doors Mounting Faceplate (required for installation of the Andover and prairie Doors) may be covered over with noncombustible facing materials.

To install Tile, Marble, Slate, Stone, Rocks or other noncombustible to enhance the arch shape of the Andover Doors or the Rectangular shape of the Prairie Doors, do so only after the Andover or Prairie Door Kits have been installed on the DXV-45 Fireplace.

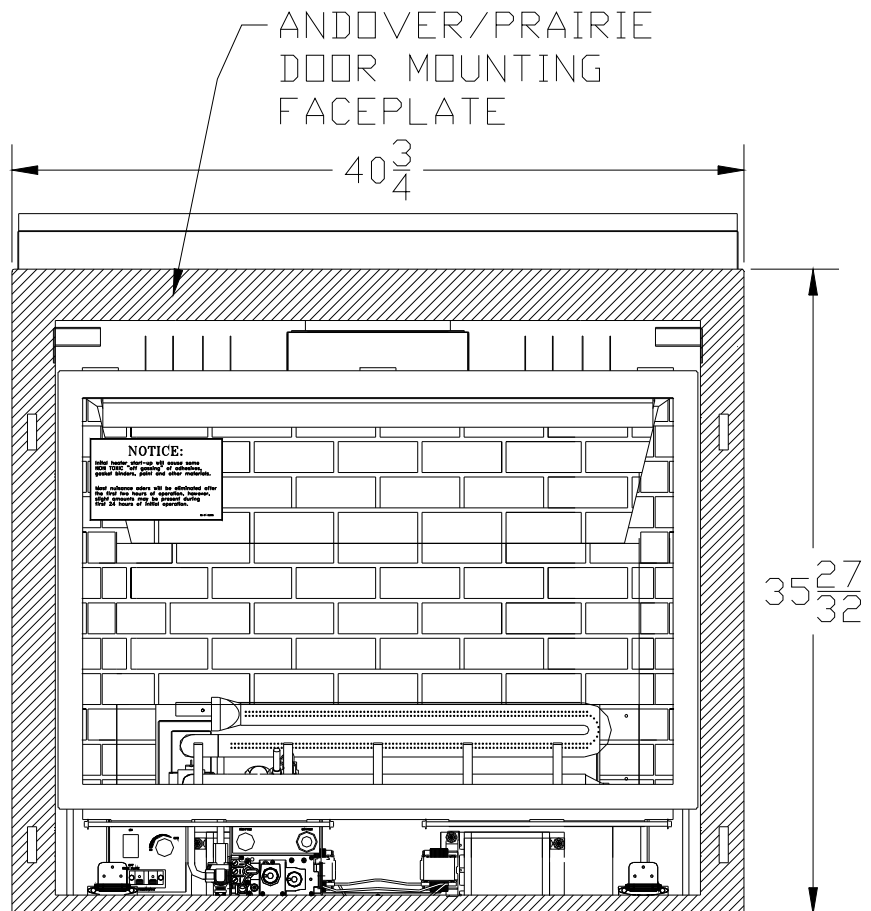

Hearth Protection Pad Installation Information when planning to Install the Andover or Prairie Fronts

Any hearth protection pad installed in front of the DXV-45 Fireplace must be designed, built and installed so that the hearth protection pad's top surface is flush with the bottom-most surface of the DXV45 Fireplace. See the diagram to the right.

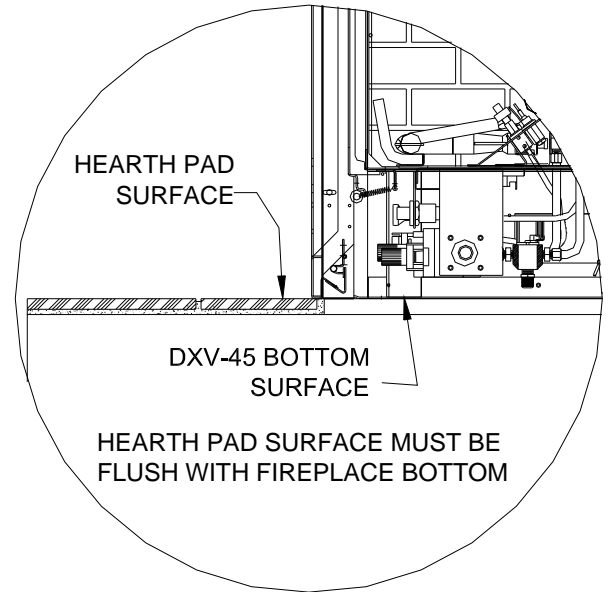

Information specific to the installation of Millennia Flat Grills, Victoria Filigrees and Tuscany Filigrees

The Millennia Flat Grills, Victoria Filigree and Tuscany Filigree are designed to be "inside-fit" trim kits. All of these trim kits fit within the inner perimeter of the Fireplace's Faceplate and remain flush within the Faceplate's front surface, see Figure below. This fitting method allows flexibility in covering the black visible surface of the Faceplate with non-combustible materials such as Tile, Marble, Slate, Stone and Brick; as long as enough room is allowed for the removal of these Mendota Designer Fronts and the glass door for servicing,

WARNING: COMBUSTIBLE MATERIALS MUST NOT COVER THE FRONT SURFACE OF THE FIREPLACE'S FACEPLATE.

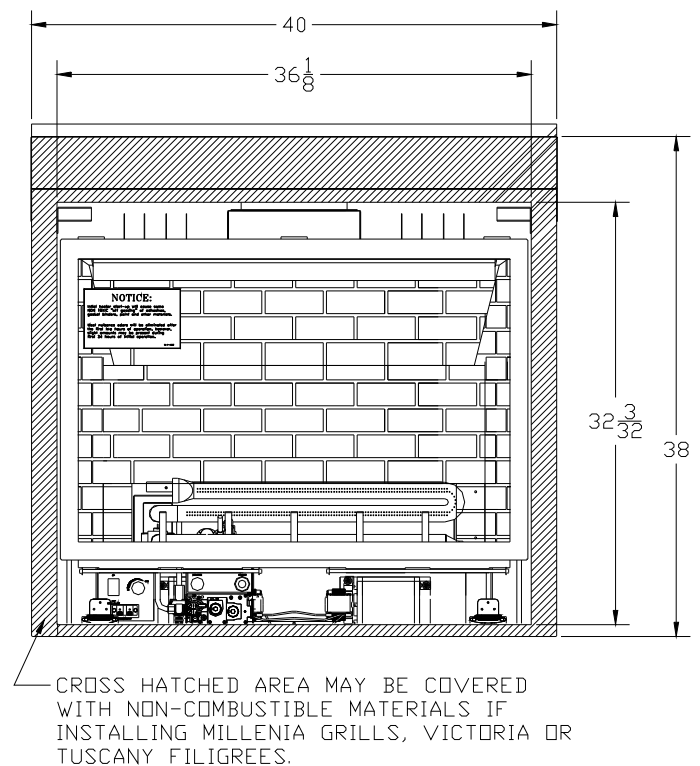

DOOR REMOVAL AND REPLACEMENT

CAUTION: Do not operate the appliance with glass removed, cracked or broken. Replacement of the glass should be done by a licensed or qualified service person. Glass latch tool #HA-57-00743 is supplied with the unit.:

To Unlatch Glass Frame Latches:

1. Insert Glass Latch Tool into hole in latch (two latches exist at top of glass frame).
2. Pull Glass Latch Tool outward about 3/8".
3. Rotate Glass Latch Tool 90 degrees.
4. Slowly Release Glass Latch Tool.
5. Remove Glass Latch Tool.

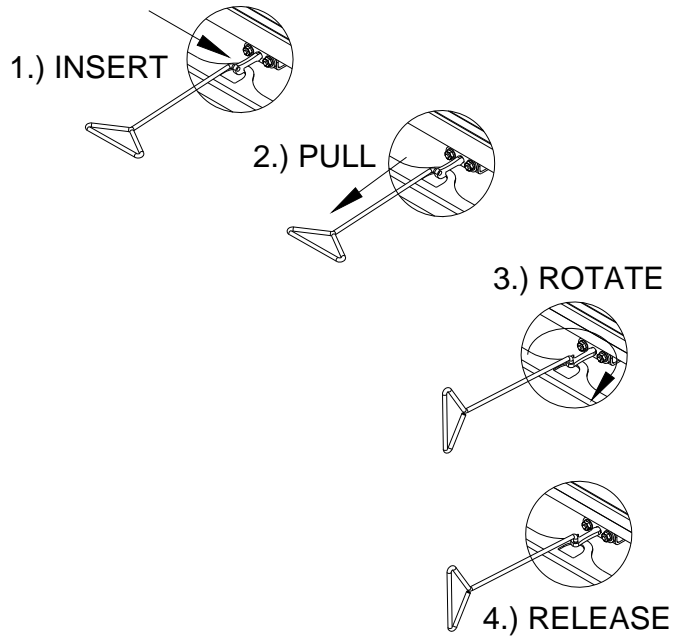

To Latch Glass Frame Latches, **reverse steps 5 to 1, above.**

To Remove Glass Frame:

1. Rotate top edge of freed glass frame outward about 15 degrees.
2. Lift Glass Frame Up and Out.

To Install Glass Frame:

1. Align and insert tabs in side flanges of Glass Frame into Slots into the slot in the side bracket.
2. Rotate Glass Frame upward until vertical.
3. Latch Glass in place per instructions above.

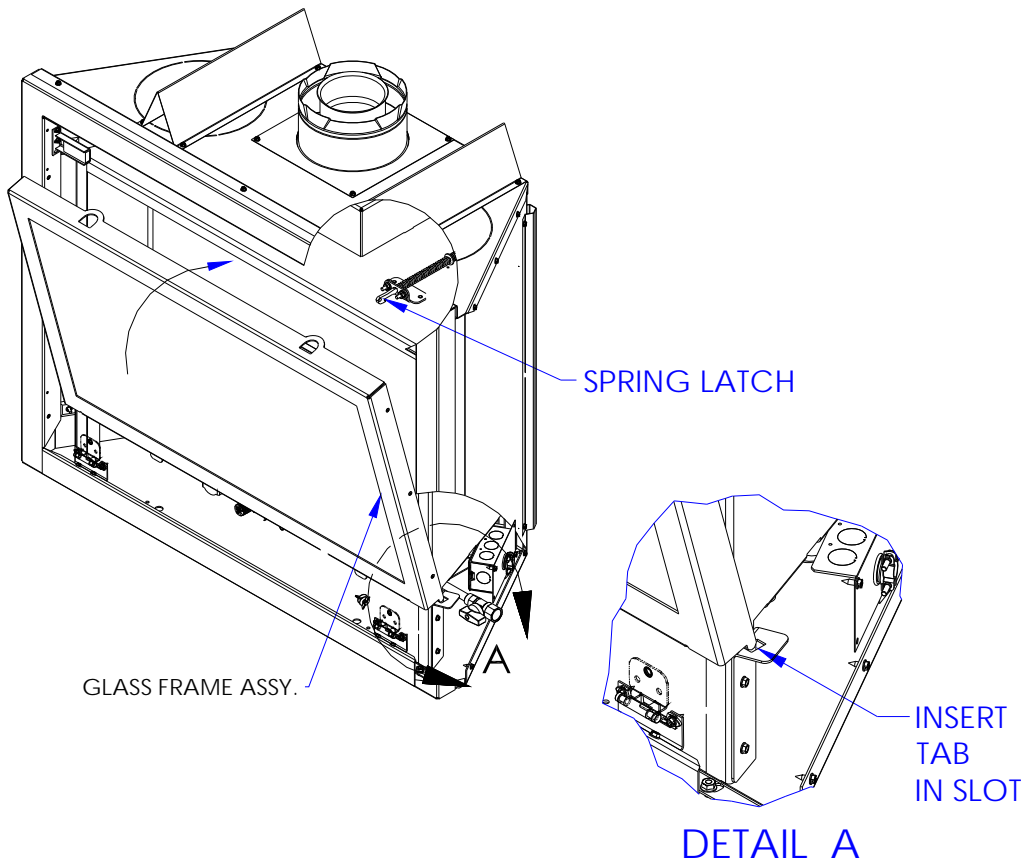

GLASS FRAME ASSEMBLY REPAIR AND REPLACEMENT

DO NOT substitute other manufacturer's materials or components.
DO NOT operate unit with cracked, broken or missing glass.
DO NOT abuse the glass door by striking the glass, slamming the door shut, etc

WARNING
 Use only authorized parts and materials obtained from Johnson Gas Appliance Company when replacing defective or damaged glass.

WARNING
 Do not operate this appliance with the glass removed, cracked or broken. Glass should be replaced by a licensed or qualified person.

TO REPLACE DAMAGED GLASS

Using an 1/8" drill bit, drill through 3 rivets on each side of glass frame. Remove glass retainer brackets and the damaged glass and gasket material. Clean the inner surface of the glass frame. Assemble new gasket on glass edge starting with the bottom left corner. The adhesive on the gasket should make contact with the glass surface. Use tracer lines in gasket to determine where the glass should sit on the gasket surface. Place glass and gasket assembly in glass frame. Carefully attach glass retainer brackets to sides of glass frame using new 1/8" Aluminum rivets.

The glass frame assembly and its individual components are available through Johnson Gas Appliance Company. Contact your dealer for more detailed ordering information.

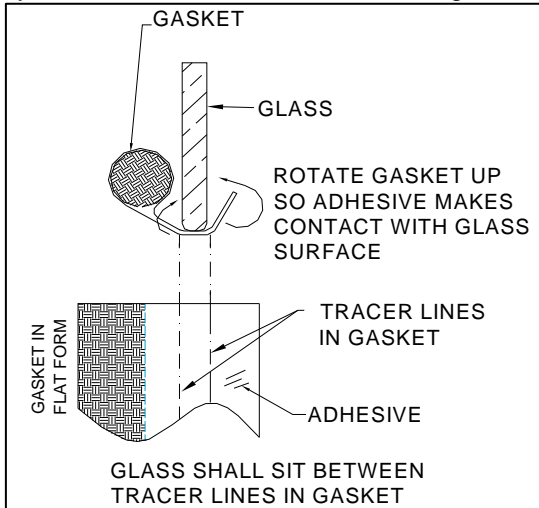

GLASS FRAME ASSEMBLY REPLACEMENT PARTS LIST		
ITEM	PART NUMBER	DESCRIPTION
1	HA-41-00313	GLASS FRAME, DXV45
2	65-02-00103	GASKET, TADPOLE, 3/8" BULB, 3/4" TAIL
3	65-06-00658	GLASS, CERAMIC, DXV45

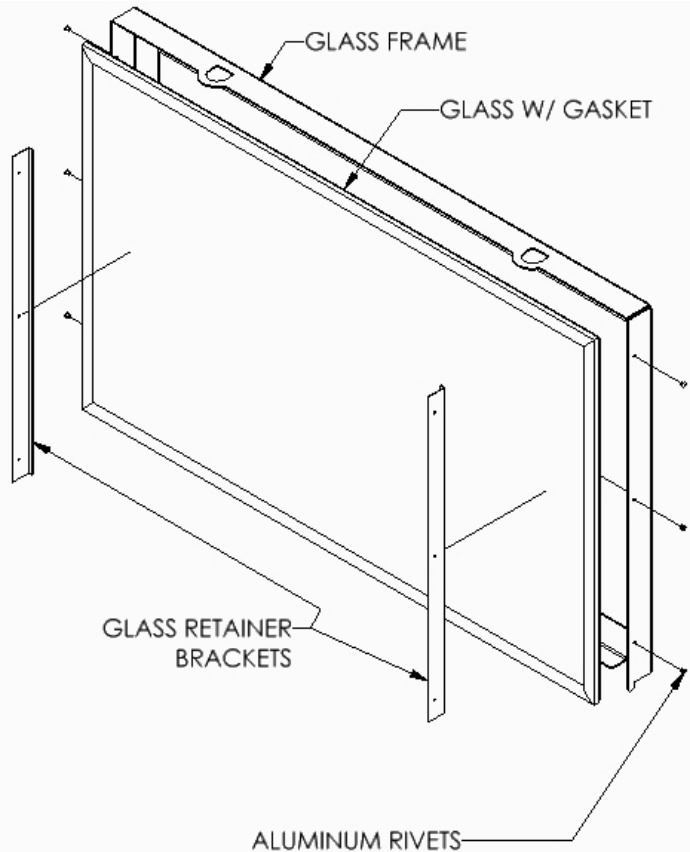

DXV45 COAL BED AND LOGS INSTALLATION

Carefully unpack the shipping boxes containing the coal bed sections and logs and remove them gently from the foam packing. 10 Log pieces, one 24 oz bag of small coals and one bag of inswool/Rockwool are included.

Lay out the log pieces on a soft flat surface and arrange them according to the diagram, below, to aid you in through the installation process.

DXV45-DT3 LOG SET PARTS IDENTIFICATION

Also included but not shown here are a 24 oz. bag of small coals and one bag of Inswool.

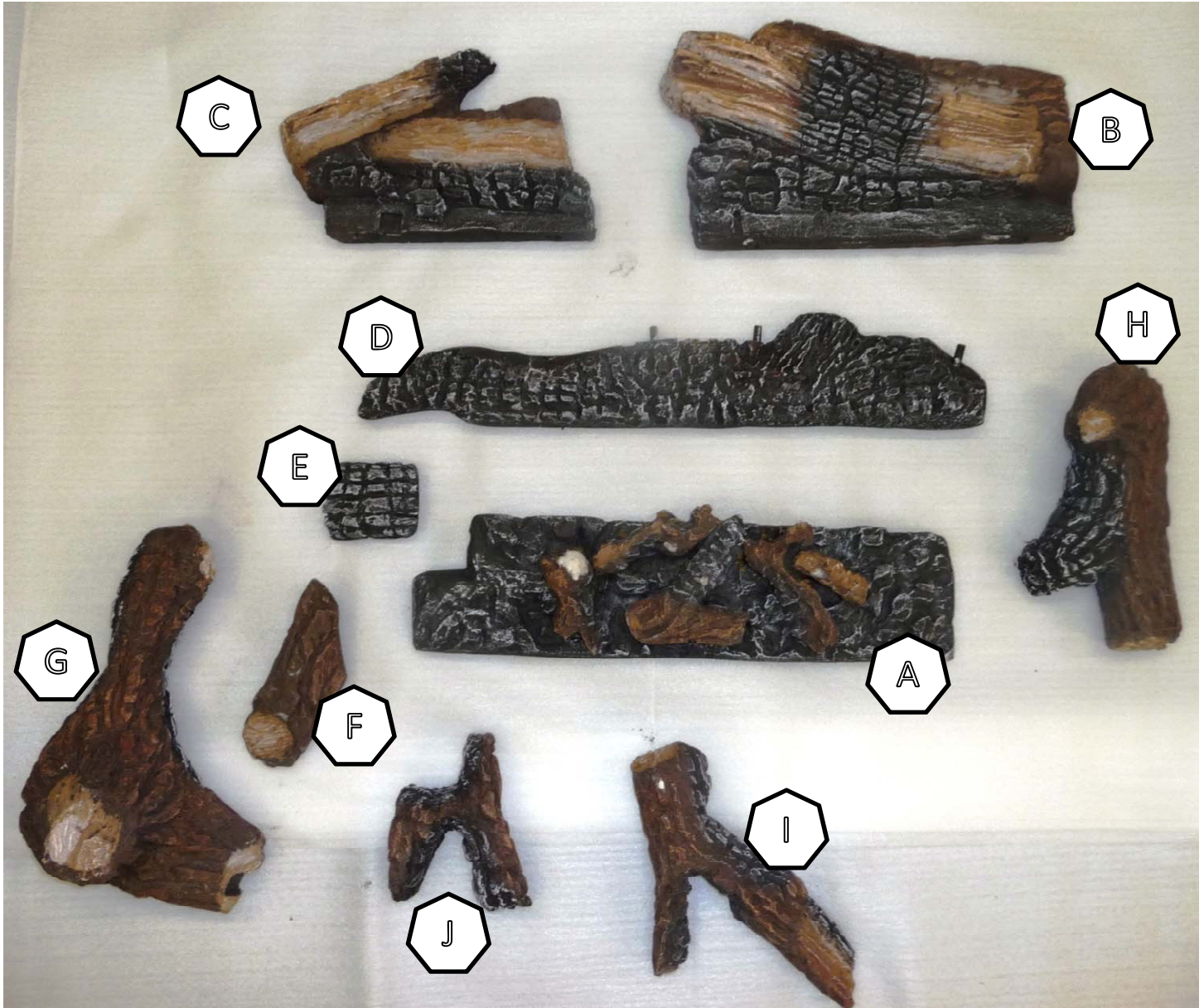

DXV45-DT3 LOG SET INSTALLATION INSTRUCTIONS



1. Locate Fiber Coal Bed "A". This Fiber Coal Bed installs between the front burner and the front of the rear burner tube as shown below.
2. The Fiber Coal Bed "A" is placed directly behind the front burner. The Coal Bed's front edge must touch back edge of front burner tube.
3. Slide Fiber Coal Bed "A" to the left as far as possible. The left edge of this Coal Bed shall touch propagation leg of front burner tube.



Front Edge of Coal Bed "A" shall touch back edge of Front Burner

Left Edge of Coal Bed "A" shall touch right edge of T- Propagation tube.



4. Locate Log "B" - Back right log.
5. Locate holes on bottom of log.
6. Place log "B" onto the 2 pins on right side behind the rear burner as shown.



Holes in bottom of Log "B".



7. **MAKE SURE THERE IS NO AIR SPACE DIRECTLY UNDER THIS LOG.**
8. While pushing log "B" down, put your fingers behind the top of log "B" to get a slight angle forward of about 10 degrees.



Log "B" installed correctly

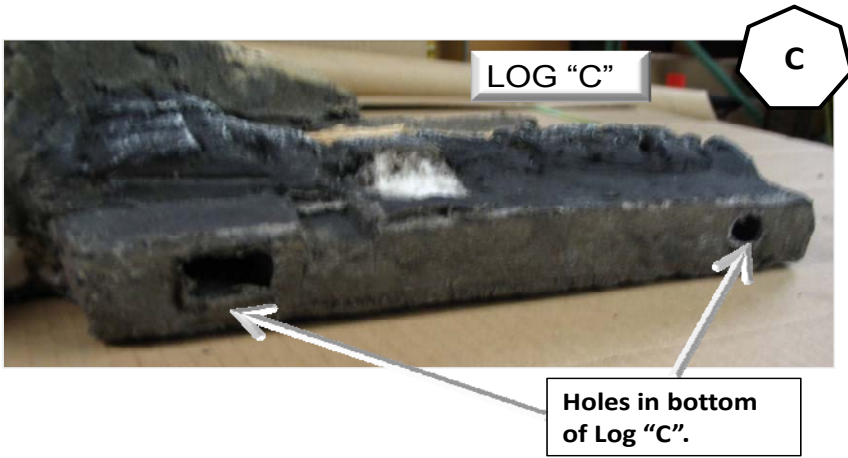

9. Identify Log "C". Back left log.
10. Locate holes on bottom of log.
11. Place log "C" onto the 2 pins on left-side behind the rear burner as shown.

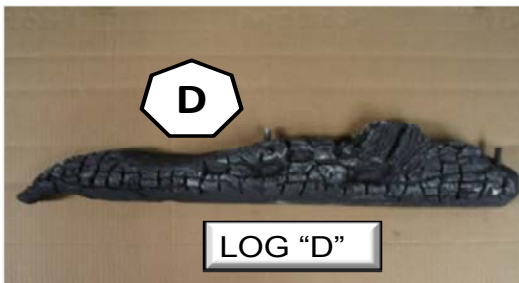

12. Identify Log "D". This log will be installed between the front and back of the rear burner tube as shown below.
13. Note that on the left end of log "D" is a curvature [along the bottom edge].



14. The curvature on the bottom left side sits on top of the rear burner's inlet tube.
15. Log "D" will be tipped slightly forward to a maximum of a 10 degree angle once logs "G" & "H" are installed.



Push log "D" up against inside curve of burner.



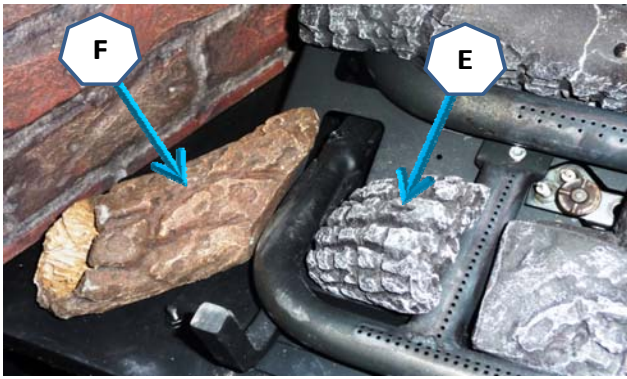

16. Identify Log "E" and Log "F". Log "E" rests on left side of the T-propagation tube . Log "E"'s left edge rests against the front burner inlet tube, at floor level.
17. Log "F" sits on the firebox floor and against the left side of the inlet tube on the front burner. Push this log back as far as possible.

18. Identify Log "G" and locate the hole at its bottom surface. Log "G" will be installed on the left side of the fireplace, with the hole on the bottom of the log setting on the left pin in log "D".

NOTCH



HOLE IN LOG "G" IS LOCATED UNDER HERE!

19. The front end of log "G" is notched. The notch will rest on the left-most grate bar.



Log "G" position on front grate



20. Identify Log "H". Log "H" will be installed on the right side of the fireplace, with the hole on the bottom of the log setting on the right pin in log "D".
21. The front end of log "H" will be resting to the right end of the front burner tube as shown.



HOLE



Log "H" front tip sits on flat crimp of front burner



HOLE IN LOG "H".



22. Identify Log "I". Log "I" will be installed in the middle of the fireplace, with the hole on the bottom of the log setting on the middle pin in log "D".

23. Once Log "I" is pinned to the middle pin in Log "D", rotate FRONT –MOST TIP of Log "I" so that it is 2 inches to the left of the Right-Most Grate Bar.

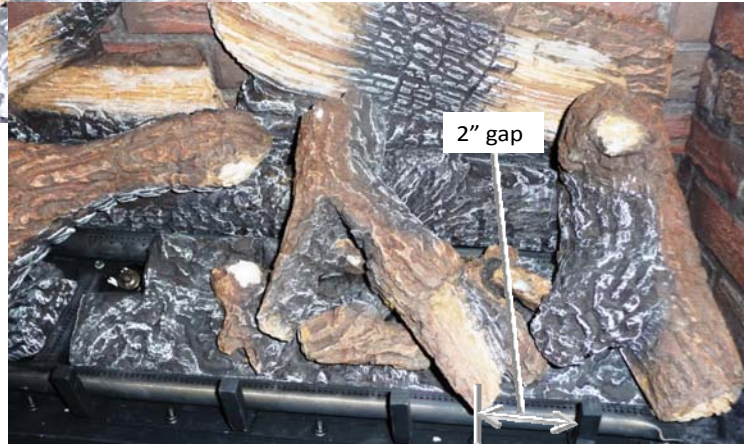

24. Identify Log "J". This log is designed to hide the pilot light flames and also to aid in the front ember-bed glow effect and realism.

25. Place Log "J" as shown here. You will find that it sits down well and "self-positions" on the ember bed. You may rotate the position of this log as it suites your taste. Exact position is not critical.



Place small coals between Firebox Front and front Burner. Pile the coals higher near the Front burner to build height. Any excess coals should be spread on the far left and far right sides of firebox to extend the coal bed effect. A couple of coals may be place behind front burner tube on Ember Bed "A" but sparsely. Avoid covering front burner tube's gas ports.



Hold a clump of Inswool/ Rockwool in one fist tightly with a small portion protruding out. Brush Inswool/Rockwool over top of front burner tube, over Ember Bed "A" and over entire log assembly. Brushed Inswool deposits should be a thin layer but enough to hide the front burner tube. Brush generously over front ember bed and all logs. Also brush lightly over center burner tube and rear burner tube. Be carefully when brushing on middle and rear burner tubes. Do not deposit large chunks of inswool on middle or rear burners. Attempt to break inswool into small fibers as you brush.



FINAL LOG SET, COALS AND INSWOOL LAYOUT RECOMMENDED PATTERN

Note: Some minor adjustment to coals locations may be necessary on LP gas units. Also, some adjustment to brushed inswool thickness may be necessary if inswool brushed over middle or rear burner are too thick and heavy and impede combustion air flow to burner.



COMPLETED LOGS AND COAL BED ASSEMBLY EVALUATION

See the picture, shown above. This picture shows the recommended log positions. Slight variations in the position of each log is allowed. However, if any log position is significantly out of position in comparison to the diagram above and if any flames are floating off the burner surface (Ghosting) after 10 minutes of starting the fireplace, turn off the fireplace and contact your installer or fireplace dealer. Have the Installer/Dealer adjust the log positions of the logs and coals and also conduct a thorough evaluation of the venting configuration to make certain that the venting configuration conforms to Mendota's venting requirements, which are listed in this Installation and Operations Manual.

The following Check Off Lists must be completed prior to final operation of the Fireplace. Failure to do so may result in abnormal function or dangerous operation. Ignorance of these guidelines can lead to property damage, personal injury or death and the manufacturer's warranty and liabilities will be voided: Keep a record of these Check OFF guidelines for future reference. Mendota may request a certified copy of these Check OFF lists to verify compliance to these printed guidelines.

INSTALLATION CHECK OFF LIST

<input type="checkbox"/>	Co-axial vent rigid pipe, wall vent cap or roof vent cap must be installed by a Mendota approved person in accordance with instructions. All joints must be secured, "twist-locked" and leak-proof. 1000°F sealant use is recommended on the inner pipe joints of DuraVent pipe sections.
<input type="checkbox"/>	Horizontal or vertical vent cap must be installed " right-side-up " and tightly sealed to structure per instructions. Vent Caps <u>must</u> be Mendota approved. Heat Shield must be installed on Horizontal Vent Caps.
<input type="checkbox"/>	Clearances to combustibles requirements must be strictly adhered to.
<input type="checkbox"/>	Proper exterior and interior clearances for vent systems and locations for wall vent cap/roof vent cap must be maintained.
<input type="checkbox"/>	Carefully check for correct gas pressure, proper size gas lines and for gas leaks.
<input type="checkbox"/>	115 V electrical service and gas supply must be installed in accordance with instructions and local and national codes.

LIGHTING CHECK OFF LIST

<input type="checkbox"/>	All items on "Installation Check Off List" (see above) <u>must</u> be completed.
<input type="checkbox"/>	Connect thermostat, if desired. Disconnect wires connected to Main On/Off switch and connect thermostat lead wires to these two wires and run to thermostat location.
<input type="checkbox"/>	Check air shutter opening - 1/16" to 1/8" Nat. gas or 1/4" Min. LP gas.
<input type="checkbox"/>	Carefully follow all Lighting and Log Installation Instructions.
<input type="checkbox"/>	Make certain that burner lights <u>immediately</u> and flame runs promptly around "curve" in burner and lights entire burner. DO NOT proceed with operation unless burner cycles "on/off" without delays.
<input type="checkbox"/>	Make certain that the flame is "stable" and does not "lift" off burner. If flame lifts off burner, turn unit off and check that all vent pipes are "twist locked" and leak proof, the vent cap is "right side up". DO NOT proceed with operation if flame is "lifting off" burner. Note: do not separate telescoping sections. They <u>must</u> be used as complete assemblies.
<input type="checkbox"/>	Make certain glass door is in properly closed and "centered" in firebox opening.

BEFORE YOU BEGIN

Read this entire manual before you use your new fireplace. Failure to follow the instructions may result in property damage, bodily injury, or even death.

Intermittent Pilot Light and Standing Pilot Light Features

This gas fireplace is equipped with an electronic ignition System that first lights a pilot light then uses the pilot light to ignite the main burners. The pilot light can be set in the "Standing Pilot" mode to allow the pilot light to remain on indefinitely by toggling the "Standing Pilot Switch" to the ON position. If the "Standing Pilot Switch" is toggled to the OFF position, the pilot light will only light and remain ON while the main fireplace burners are operating.

IPI Mode

This mode turns the pilot light "OFF" when the fireplace is not functioning and only lights the pilot light automatically when a call for heat is made by the remote control.

Standing Pilot Mode

If the "Standing Pilot Switch" is toggled to ON, the pilot light will ignite and remain ON as long as the "Standing Pilot Light Switch" is in the ON position.

NOTE: Mendota Fireplaces recommends that the Standing Pilot Mode be used during the winter months when external temperatures fall below 50°F. This will keep the fireplace chimney heated for proper updraft during burner ignition and it will also eliminate excessive condensation of exhaust vapors on the door glass. Further, leaving the fireplace in the Standing Pilot Mode will keep the fireplace body warm and eliminate cold drafts and heat loss to the cold air that is trapped inside the firebox.

CONTROL PANEL FUNCTIONS IDENTIFICATION

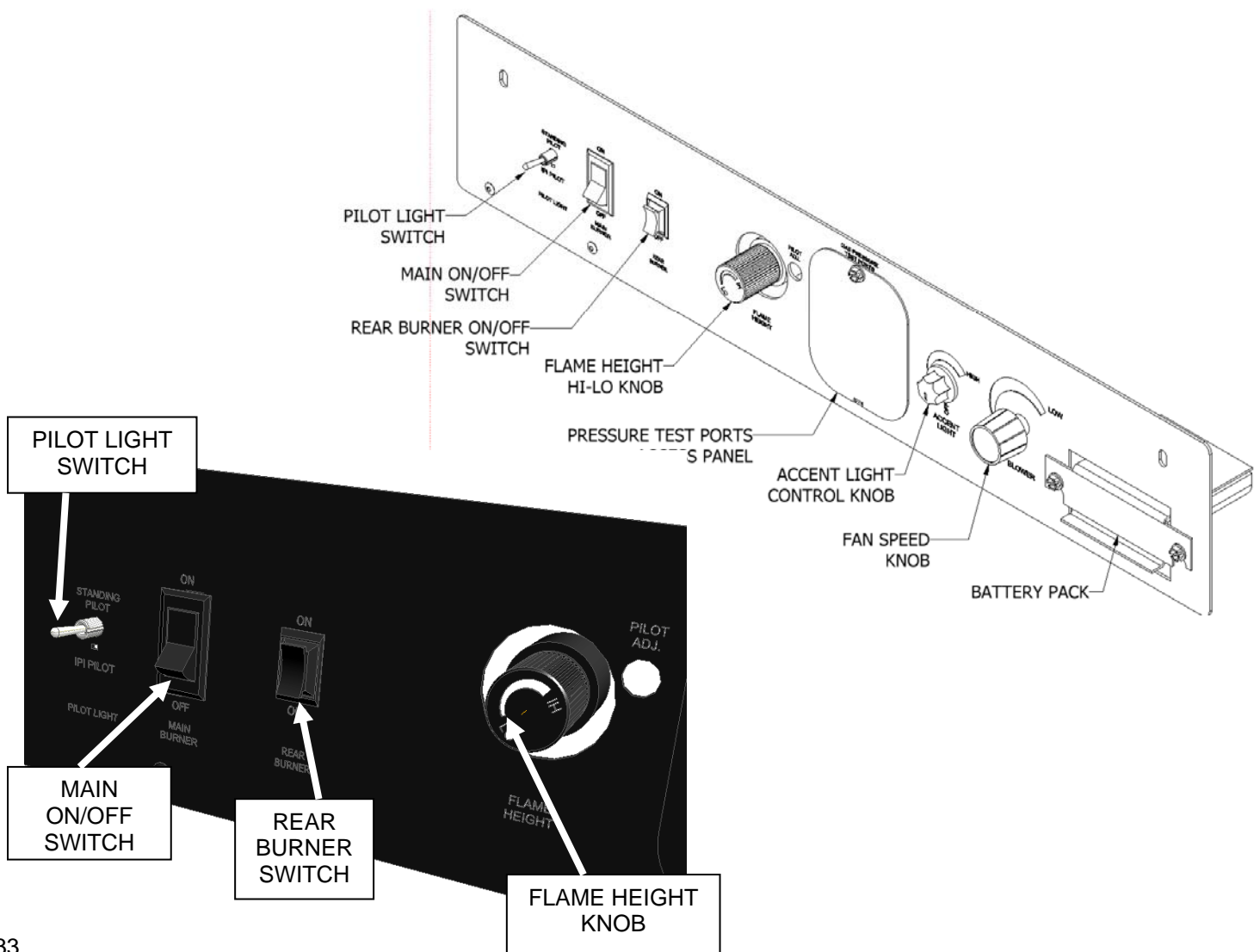

“FIRST TIME” LIGHTING INSTRUCTIONS

IMPORTANT: Be sure all items on "INSTALLATION CHECK OFF LIST" in the Installation Manual have been completed!

CAUTION: If the pilot goes out, be sure to wait a minimum of five minutes before attempting to relight the pilot.

1. Make certain that any manual gas supply shut-off valves located upstream of fireplace are open.
2. Make certain that 120VAC power is connected [and ON] to the electrical junction box on the left side of unit.
3. Insert Batteries in the Battery Holder if not already installed at the factory. Note the polarity of batteries and insert as indicated on the battery compartment covers.
4. For the “First Time Lighting”, Remove the Glass Door. This is required to purge the gas line of air and to inspect the pilot lighting spark.
5. Locate the “Standing Pilot ON/OFF Switch”. Toggle “Standing Pilot ON/OFF Switch” to “ON”. You will hear a series of clicks and after a few seconds, you will hear sparking at the pilot spark electrode. Visually inspect the spark at the pilot hood and verify that the spark jumps from the spark electrode to the pilot hood.
6. Allow adequate time for the air in the gas-line to purge. The control system will stop sparking after 30 seconds if the pilot light does not light. After a 30 second delay the control system will start sparking again for 30 seconds more. If the pilot light does not light after the third 30 second spark event, the system will enter “Lock-out” mode. To unlock from “Lock-out” mode, toggle “Standing Pilot ON/OFF Switch to “OFF” and toggle Main ON/OFF Switch to “ON”, wait 30 seconds and toggle Main ON/OFF Switch to OFF. Toggle “Standing Pilot ON/OFF Switch to ON. Repeat this sequence until the pilot flame lights and the pilot is burning steadily.

LOCK OUT MODE: If the pilot light does not light after the third 30 second spark event, the system will enter “Lock-out” mode. To unlock from “Lock-out” mode, toggle “Standing Pilot ON/OFF Switch to “OFF” and toggle Main ON/OFF Switch to “ON” (the sparking will start again); wait 30 seconds and toggle Main ON/OFF Switch to OFF. This will reset the system.

7. Once the pilot flame is lit and well-established, close glass door. **WARNING: NEVER IGNITE MAIN BURNERS WITH GLASS DOOR REMOVED OR OPEN.** Doing so will lead to damage to pilot flame sensor wire and spark electrode wire leads.
8. Toggle Main Burners ON/OFF Switch to “ON”. All burners should ignite and run at “high-fire”. If rear burner does not turn ON, toggle Rear Burner ON/OFF Switch to ON. After 15 seconds, Toggle Main Burners ON/OFF Switch to OFF. Burner Flames will extinguish.
9. Perform gas inlet and outlet pressure tests and leak tests on field installed gas fittings and factory installed fittings in the gas valve compartment, at this time. Note: Burners must be ON to check outlet pressures and to leak test gas train fittings upstream of main gas valve.

Backup Batteries: The life span of the backup batteries depends on the quality of the batteries used and how long the batteries have been installed in the wall receiver. These batteries are only utilized during power outages. Replace these batteries every heating season even if you have not experienced any power outages. Batteries drain slowly even when not in use. This is a normal characteristic of all batteries. To prevent the batteries from bleeding while not in use, you may choose to remove the backup batteries and install them only when they are needed.

OPERATING DURING POWER OUTAGES

This electronic ignition system utilizes the supplied 110VAC power when it is available for all functions of this system. If the AC power is interrupted during a power outage, this system utilizes the batteries (installed in the Wall Receiver) as back-up batteries. During the power outage, the appliance’s burners will function. In addition, Flame Height adjustment and Secondary Burner ON/OFF functions will be available. The Fan and Accent Light, which are wholly dependent on 110VAC power, will not function.

This appliance is designed and tested to be operated during power outages. The overall efficiency of this appliance will be reduced by approximately 5% when the blower function is disabled during the power outage period.

THERMOSTAT OR REMOTE CONTROL OPERATION

The Fireplace may be connected to a wall thermostat, a remote control or a wall switch. The thermostat should be placed in the same room as the fireplace, approx. 4-5 ft. off the floor (out of reach of children). **DO NOT** place thermostat within 8 feet of this fireplace or on an outside wall.

CAUTION: In standing pilot mode, burner should light after turning thermostat "on". If burner does not come on immediately, turn the thermostat off and wait 60 seconds before turning on again. If burner does not come on immediately after second try recheck complete installation of logs, pilot, vent system, etc. **Do not** operate fireplace if burner does not light immediately. Call service technician.

NEVER TURN BURNER ON & OFF "QUICKLY" - ALWAYS WAIT 60 SECONDS BETWEEN ON AND OFF!

NOTE: The maximum length of thermostat wire allowed is 25 feet. Use of longer thermostat wires may cause malfunction of the thermostatic function. **CAUTION: NO EXTERNAL POWER SUPPLY CAN OR SHOULD BE USED.**

Use two-wire, copper lead wire per chart below and install as follows:

NOTE: Thermostat Must Be Millivolt Rated

RECOMMENDED MAXIMUM LEAD LENGTH (TWO-WIRE) WHEN USING WALL THERMOSTAT	
WIRE SIZE	MAX. LENGTH
16 GA.	25 FT.
18 GA.	25 FT.
20 GA.	25 FT.
22 GA.	18 FT.

Figure 5: Thermostat Wiring

NOTE: Thermostat must be millivolt rated (dry contact type only).

HOW TO CONNECT A THERMOSTAT OR WALL SWITCH TO THIS FIREPLACE

Remove Courtesy Panel and disconnect wires from back of Main Burners ON/Off Switch. Connect Thermostat Leads to the two wires you removed from the Main Burners ON/OFF Switch and run to the thermostat location. Connect thermostat to the wire leads. Test thermostat in Standing Pilot Mode first.

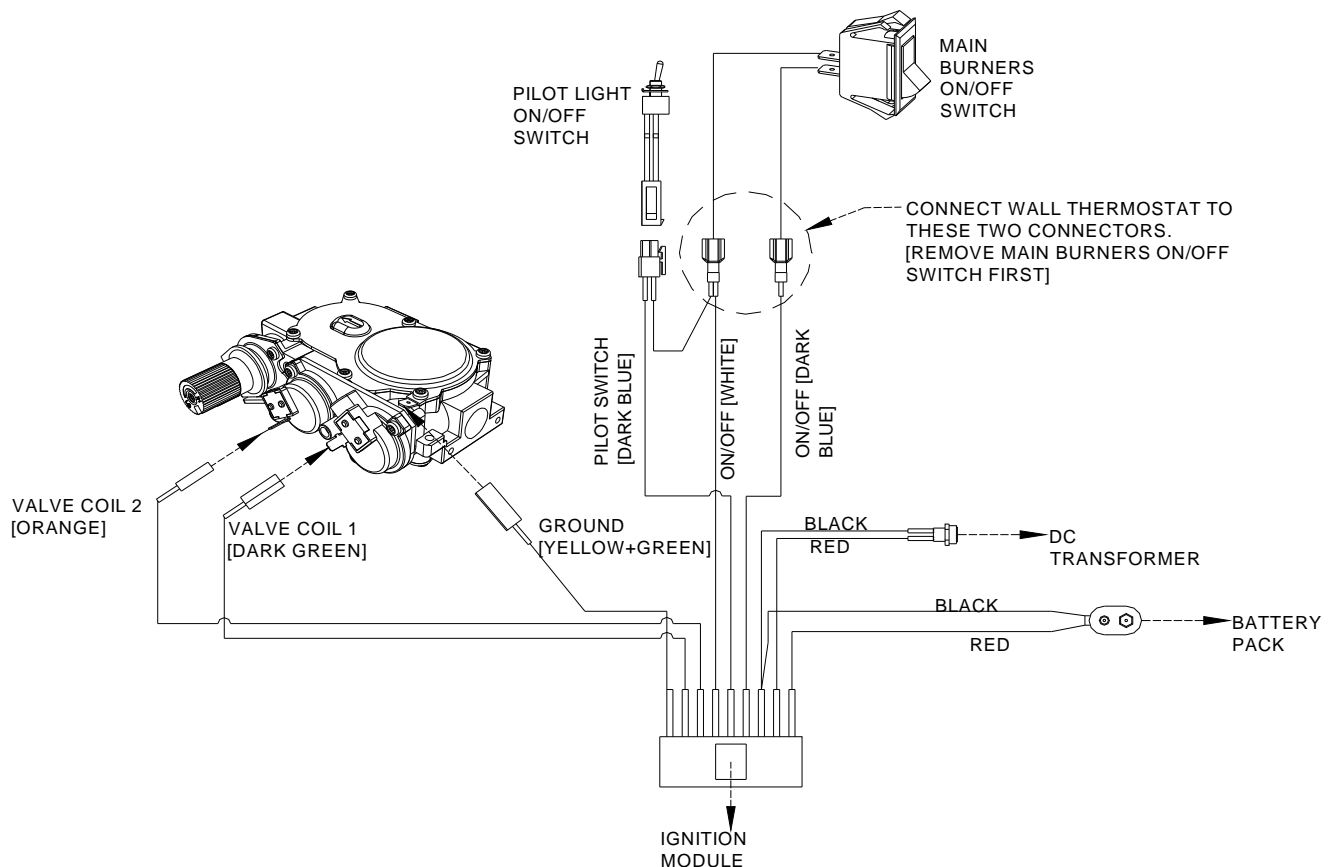

BLOWER OPERATION AND WIRING

WARNING: The Electrical Junction box within this appliance must be connected to a grounded LIVE power circuit. No switches, Light Dimmers or Fan Speed Control Devices are allowed within the same electric circuit as this appliance. Connect only to a LIVE electrical power supply that is not controlled by any other switching device.

Dual blowers are provided as standard equipment with this DXV45 DT3 Fireplace. The dual blowers have an air output rating of 210 CFM (in free air). This Fireplace is designed to operate with the blowers turned ON when the appliance is running and hot. The blowers increase the overall efficiency of this fireplace and aid in distributing and circulating heat to the room this Insert is installed in.

BLOWER BREAK-IN PERIOD: The integrated blowers in this Insert may exhibit some bearing noise and electrical static noise during the first few hours of operation. This is normal during the break-in period. It is recommended that following the Paint Curing Cycle, the blowers be run at their maximum speed for two 3-hour periods. The blowers in a few units may take longer to break-in and may require additional operation time before all extraneous noise is eliminated. Please allow adequate operational time (a minimum of 2 weeks) for the blowers to break-in before you contact your dealer for service.

WARNING: Label all wires prior to disconnection when servicing controls. Wiring errors can cause improper and dangerous operation. Verify proper operation after servicing.

BLOWER OPERATION

This Fireplace is designed so the blower operates at all times the fireplace is operating. The blower output can be regulated with the rheostat. NOTE: There will be a time delay in blower operation during "heat-up" (approx. 15 minutes) and extended blower operation during "cool-down" of unit. (Approx. ½ hour). NOTE: Power supply to blower must be continuous. DO NOT use a switch or variable speed control in power supplied to fireplace.

OPERATION DURING POWER OUTAGES

The fireplace is designed to operate during power outages for 1-1/2 continuous hours, Maximum. The blower will not operate, but natural convection can be improved by removing the upper grill and opening the screen doors (depending on the type of optional front installed). After 1-1/2 continuous hours of operation, during the power outage, turn off the burners for 1 hour and allow the fireplace to cool down. Consecutive 1-1/2 hour burn and 1 hour cool down cycles are allowed.

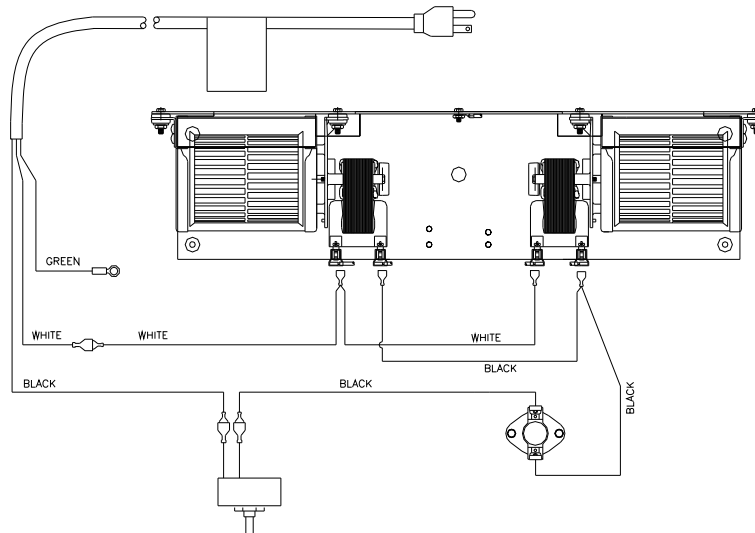

TROUBLESHOOTING MENDOTA GAS DXV FIREPLACE

SYMPTOM	PROBABLE CAUSES	CORRECTIVE ACTION
1. Thin black coating (soot) forms on viewing glass.	A. Incorrect gas pressure B. Not enough combustion air	Have gas supplier check for correct gas pressure (7" W.C. Nat. Gas; 11" W.C. LP Gas). If sooting continues open-air shutter on burner (see "Gas Flame Adjustment" below). If sooting still continues, shut off unit and call Mendota service person. NOTE: To clean glass - remove glass and wipe glass with cloth or paper towel.
2. Humming or whistling coming from Fireplace.	A. Normal operating noise. (See "Quiet Operation" pg. 25)	Some noise is normal. It is caused by the gas supply flowing through the gas orifice. It is expected from any gas fireplace. The noise can be reduced by turning the Hi/Lo Knob on the control. Turning down the flame will reduce the heat output of the unit.
3. A change in flame appearance or burner operation.	A. A change in gas pressure. B. Carbon dirt or lint.	Have your gas supplier check for correct gas 7" W.C. Nat. Gas; 11" W.C. LP Gas). If flame still needs adjustment see "Flame Adjustment" below. Clean out carbon, spider webs, lint, etc. from shutter area. Logs and burner. NEVER BLOCK AIR INTAKE OR OUTLET VENTS.

MAIN BURNER GAS FLAME ADJUSTMENT

During initial installation the burner should be removed and verified that the air shutter opening is set correctly at **1/8" to 1/4" open for Natural gas and 1/4" - 1/2" minimum open for L.P. gas.**

NOTE: For altitudes above 5,000 ft., some variations may be required.

Be sure burner and logs are properly installed. After burner has been properly installed and operated for two to three hours, small additional adjustments to the air shutter may be necessary for final flame appearance. These small shutter adjustments can be made by the following procedure:

NOTE: Very small changes in shutter settings make major changes in flame appearance.

Air shutter knob is located behind the lower grill.

If flame is too "blue" slowly push air shutter control knob in small 1/16" increments until flame turns desired realistic "orange."

If flame is too "orange" or is causing sooting on viewing glass or on logs, pull air shutter control knob outward in 1/16" increments until sooting stops. **IF SOOTING DOES NOT STOP, TURN OFF UNIT AND CALL YOUR MENDOTA SERVICE PERSON.**

The front coal bed burner is pre-set at 1/8" open. Normally, no adjustment is required. For LPG applications, a slightly larger (greater than 1/8" opening in the front burner air shutter may be required if soot deposits on front logs or on coal chunks).

IMPORTANT: Try each new shutter setting approx. ½ hour before making additional changes. **NOTE:** Changes in front burner flame can be made by re-arranging the coals. (See pg.22)

CAUTION: Any changes in pilot flame must be made by qualified person and checked with voltmeter.

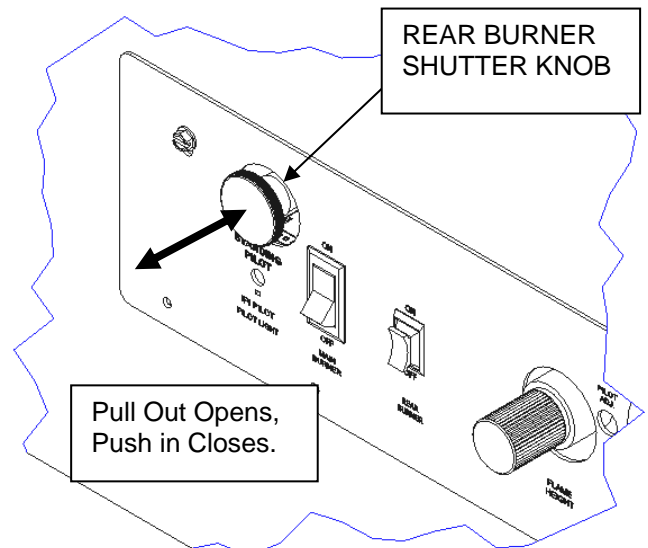

CUSTOMER INFORMATION AND TROUBLE-SHOOTING

MAXIMUM ALLOWABLE SURFACE TEMPERATURES

Mendota Fireplaces comply with UL Standards for maximum surface temperatures on exposed and embedded combustible surfaces adjacent to the unit. The Maximum allowable surface temperature is 117° F. over ambient (room) temperature on exposed surfaces. Thus, if a room is 70° – 80° the exposed combustible surfaces immediately surrounding the Fireplace can have a surface temperature as high as 187° F. – 197° F. (too hot to touch). The continuous blower operation automatically keeps temperatures within these safety limits. During Power Outages, remove upper grills on Millennia Fronts, open doors on Andover and Prairie Fronts and remove upper grills, remove Victoria and Tuscany Upper Face. This will increase convection air flow and prevent overheating.

OVER FIRING OF BURNER

NEVER "over fire" **units** by adjusting gas pressure or drilling out the orifice to increase BTUH above nameplate specifications. Over firing can cause permanent damage to firebox and deterioration of parts and void warranty.

MAINTAINING CORRECT PILOT FLAME - PILOT OUTAGE & RELIGHTING

Never lower (reduce) pilot flame length less than 1 inch long.

If pilot goes out, be sure and wait a minimum of 5 minutes before attempting to e-light the pilot flame.

CLEANING VIEWING GLASS

CAUTION: Do Not use oven cleaner to clean glass. The viewing glass should be cleaned periodically. Exterior glass may be cleaned with cleaner as desired. Interior glass - use soap and water, Kel Kem Glass Cleaner or equivalent.

NOTE: Additives that are put in gas (both natural and propane) to make it smell, can be harmful to glass and can leave a white film deposit on the glass. This deposit can be removed with cleaners such as KEL KEM "Polish Plus" or comparable product (See your dealer).

In some cases (especially propane) additives can cause "crazing" or etching on the glass. Although this is not normal, it is not covered under the warranty. The solution may be to change propane suppliers.

SOOTING

Sooting is caused by improper installation or improper burner air shutter operations. However, some small areas of soot deposits on log surfaces are deemed acceptable. Open the burner air shutters if you observe sooting. If you observe large soot areas (larger than 1"x2") on log surfaces or signs of sooting on the door glass (usually a thin black film on the Fireplace viewing glass or on the outside of the home around the vent cap), open both burner air shutters fully. If sooting continues, the unit must be immediately turned off and the local Mendota dealer promptly informed. Mendota dealers will correct "sooting" problems, but Mendota and their dealers are not responsible for damage caused by excessive sooting that has not been immediately brought to their attention.

OPERATION DURING POWER FAILURE

The fireplace is designed to operate for a maximum of 1-1/2 hours continuously during power outages. Turn off all burner flames and let unit cool down for 1 hour after the 1-1/2 hour operation during a power outage.

Hot air convection can be improved by removing upper grill and opening bottom grill. During a power outage, Hot air convection must be improved by removing upper grill of the Millennia Fronts, opening the doors on the Andover and Prairie Fronts and opening the screen on the Wellington Front. Remove any inner grills that may cause air flow restriction. Replace these parts for operation after the unit has cooled completely and power is restored.

MAINTENANCE

ANNUAL MAINTENANCE OF THIS MENDOTA FIREPLACE IS REQUIRED.

The following procedures must be performed each year by a Mendota approved service person. NOTE: Any adjustments to burner, pilot or logs must be done by a qualified Mendota service person.

- A. Replace backup batteries at least 2 times annually. Replace them when the Day Light Savings Time changes.
- B. Clean all lint and dust build-up around the control. Inspect the condition of any wiring under the burner for melting or damage.
- C. Remove logs & coals and clean away any foreign matter (lint, Carbon, etc.) on the burner and logs. Be sure the burner ports are "open". Clean the pilot and under side of the logs for any Carbon deposits. NOTE: Logs should be visually checked for Carbon "build-up". If carbon deposits are visible on logs, unit should be turned off and Mendota service person contacted. Be sure logs are re-installed per instructions.
- D. Check condition of glass door gasket, gasket must seal tightly over firebox, replace if necessary.
- E. Periodically check to verify that the vent system and vent cap are open and free of blockage.
- F. Before re-installing glass, have qualified service person check the operation of the pilot
- G. The viewing glass should be cleaned periodically. Exterior glass surface may be cleaned with cleaner as desired. To clean Interior glass surface, use Kel Kem "polish plus" (part # 65-06-00455) or comparable product. Do not use oven cleaner or abrasive cleaners to clean glass. Do not clean when glass is hot.
- H. Periodic visual check of pilot flames and the pilot ignition spark system is required. Pilot lighting Spark must originate on Pilot Spark Rod Tip and end at Pilot Hood every time the system initiates a spark. Pilot flame must ignite within 5 sparks once gas flows out of pilot hood. Pilot Flame must be at least 1-inch long and must overlap Flame Sensor and burner ignition ports at all times.

Periodic visual check of main burner's rear and front flames is required.

WIRING SCHEMATICS

Note: The DXV45 DT3 ignition system utilizes Transformed DC power for normal ignition functions. In the event of a power outage, the Battery Pack power is utilized.

IGNITION SYSTEM WIRING SCHEMATIC

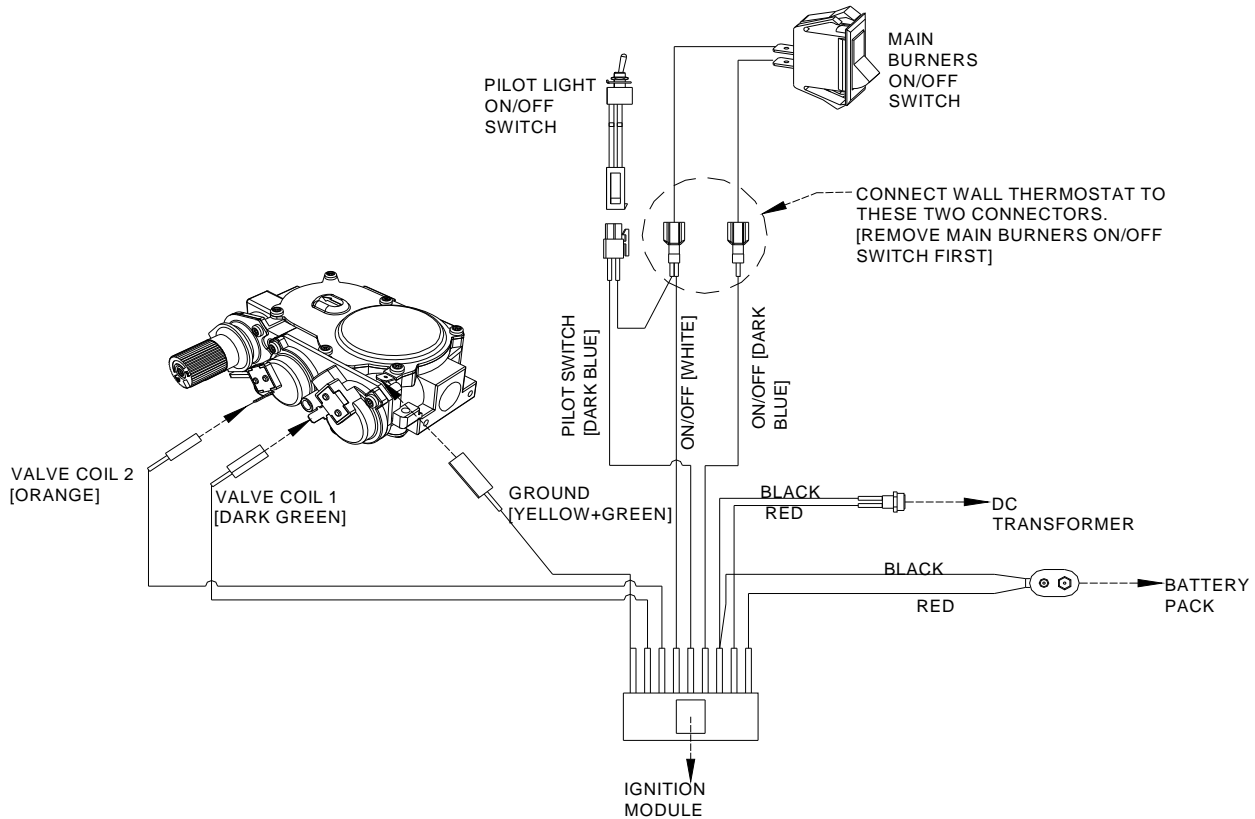

BLOWER SYSTEM WIRING SCHEMATIC

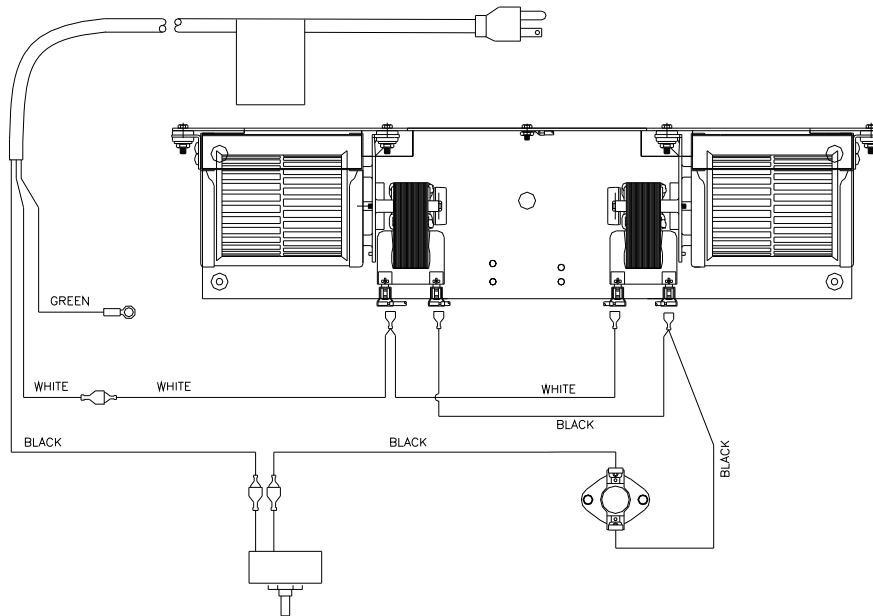

NATURAL TO LP GAS CONVERSION INSTRUCTIONS

Kit # HA-42-00225 Mendota Model DXV45-2011

This conversion kit shall be installed by a qualified service agency in accordance with the manufacturer's instructions and all applicable codes and requirements of the authority having jurisdiction. If the information in these instructions is not followed exactly, a fire, explosion or production of carbon monoxide may result causing property damage, personal injury or loss of life. The qualified service agency is responsible for the proper installation of this kit. The installation is not proper and complete until the operation of the converted appliance is checked as specified in the owner instructions supplied with the kit.

Caution: The electrical supply to the fireplace must be turned off prior to performing the conversion. The gas supply must be shut off prior to disconnecting the electrical power.

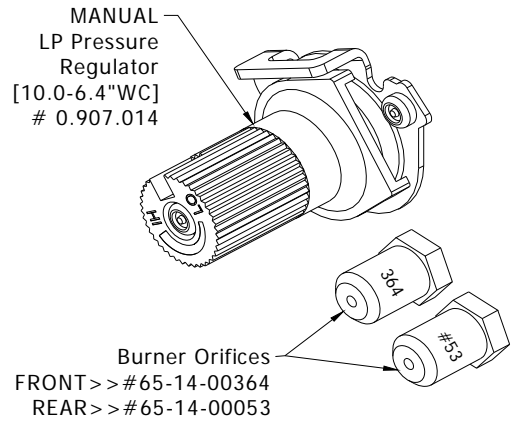

ORIFICE SIZES REQUIREMENT:

LP Conversion Kit # HA-42-00225 contains the following parts: One Manual LP Pressure Regulator #907.014, one Cap Orifices #65-14-00364 (drill #3/64"), one Cap Orifice #65-14-00053 (drill #53) and an L-shaped Torx wrench.

RECOMMENDED PROCEDURE TO CONVERT THIS FIREPLACE TO BURN LPG

This Fireplace Insert arrives from the factory ready to burn Natural Gas. If you intend to burn LPG, it is highly recommended that you convert this fireplace and its Pressure Regulator, Pilot Orifice Thimble and Burner Orifices prior to placing this fireplace in its fireplace cavity.

See diagrams, on this page, and follow these instructions to prepare this fireplace for conversion to LPG.

1. Using a 1/4" Hex Driver, remove screws that secure the Rear and Front burners to the Burner Airbox.
2. Pull forward and remove Front Burner.
3. Loosen Front Burner Air Shutter Screw and rotate air shutter open 1/4" minimum. Secure Air Shutter Screw. Set burner aside.
4. Pull Rear Burner forward about 1" and lift up and remove from Firebox.

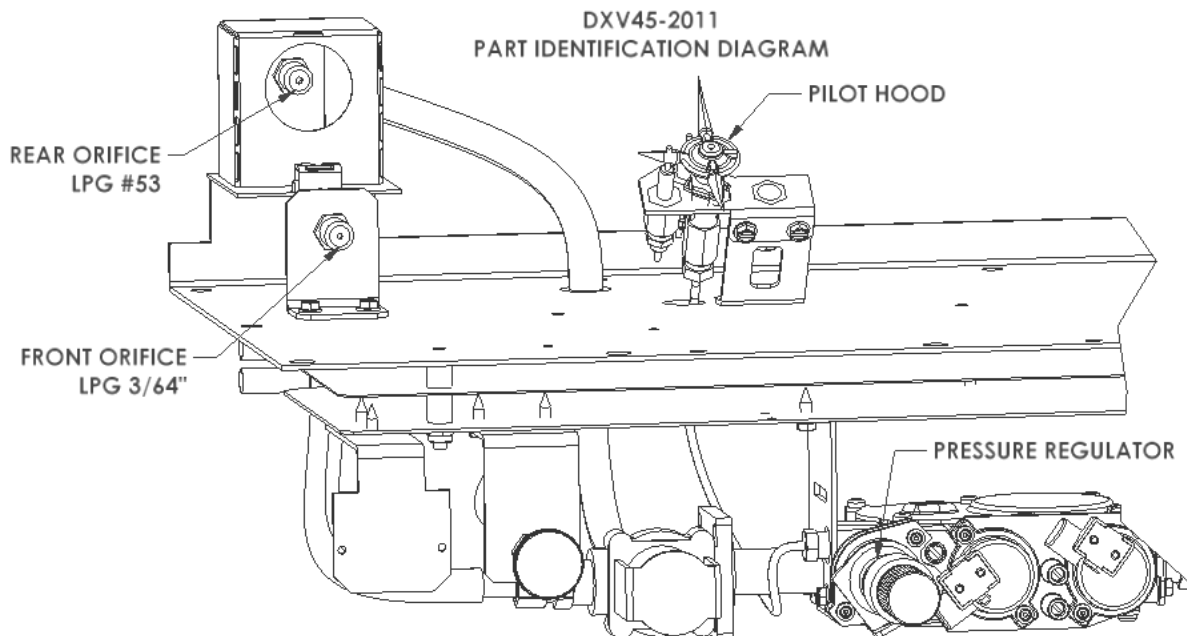

- Using a 1/2" deep well socket wrench, remove Front and Rear Orifices.

HINT: PACK SOME SOFT PAPER OR INSWOOL INSIDE DEEP WELL SOCKET TO STOP CAP ORIFICE FROM SLIDING TOO FAR INTO THE SOCKET.

- Thread a new 3/64" drilled orifice to the Front Orifice mounting brass fitting and new #53 drilled orifice to the Rear Orifice mounting brass fitting. Tighten down orifices.
- Locate Pilot Light on left side of firebox. While holding the pilot base body with large vice grips tightly, loosen Pilot Light's hex shape base using a 1/2" open end wrench. Rotate counter clock-wise 1/4 turn to loosen.
- Pilot arrives from the factory set for NG. Push NG/LP Adjustment Clip inward all the way to set it for LP. See detail view, below. If you see "NAT" printing on the Adjustment Clip, this indicates that the pilot is set to burn NG. Push Clip in so that "NAT" is not visible.
- Tighten down Hex shaped base of pilot using a 1/2" open end wrench.

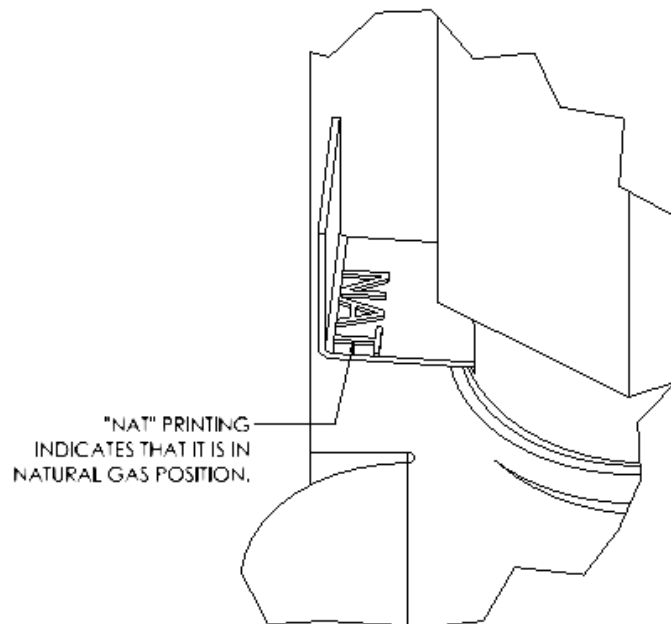
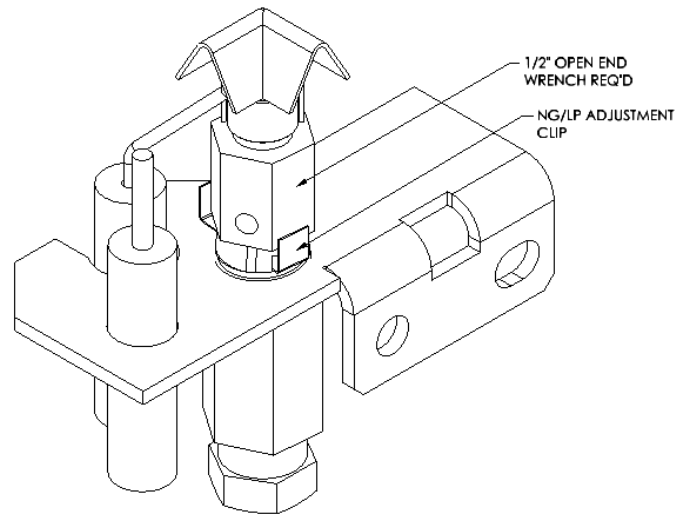

Before reinstalling burners, loosen the screw that secures the rotary air shutter on the Front Burner. Rotate the air shutter open to ¼" minimum.

10. Install both rear and front burners in their original locations and positions and secure down using screws you removed earlier.

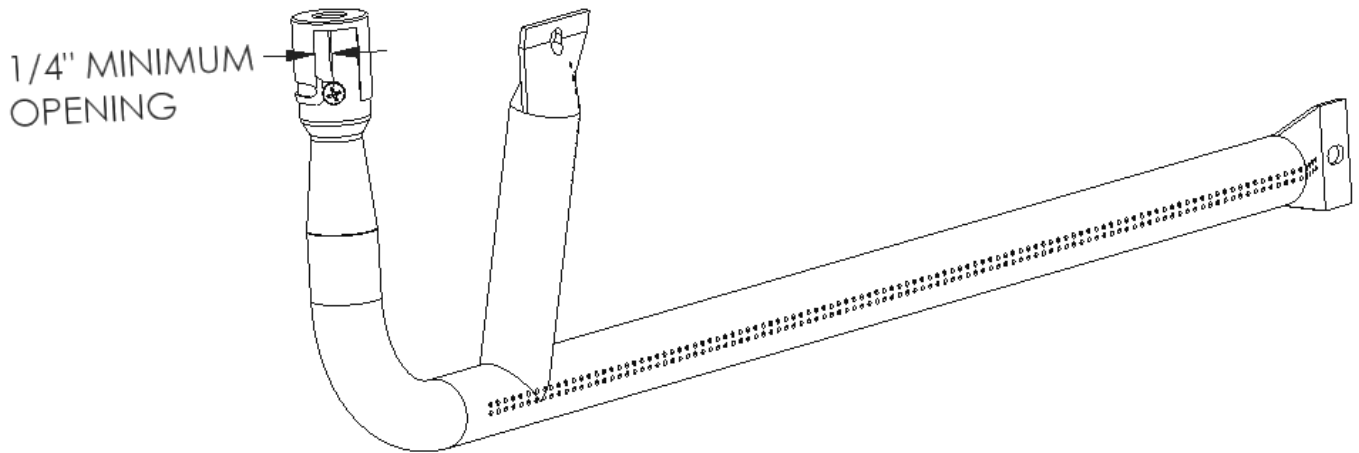

11. Make certain front and rear burners are running parallel to front face of unit and positioned properly so that the pilot light flames are pointed properly towards the burner's flame propagation ports.

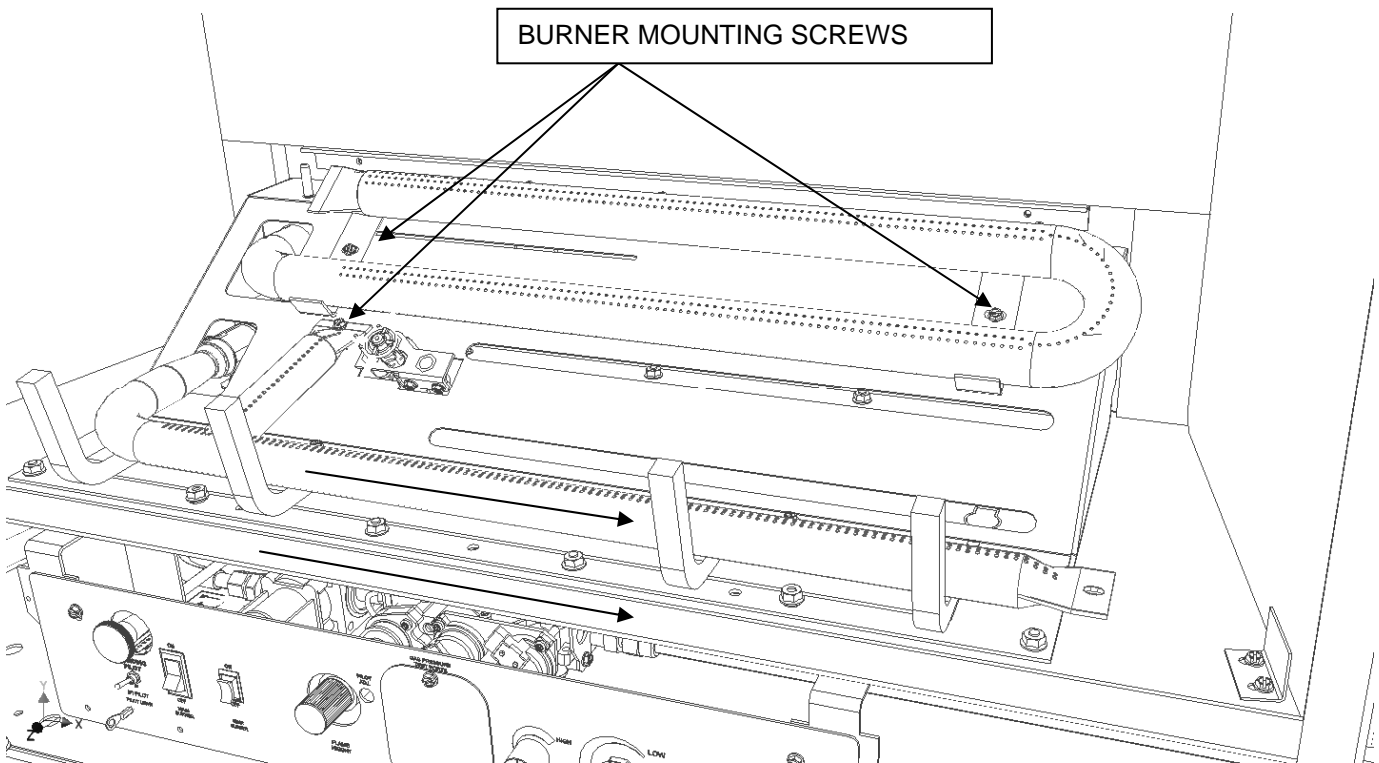

INSTALLING THE LP PRESSURE REGULATOR

WARNING: READ AND UNDERSTAND ALL INSTRUCTIONS PACKAGED WITH LP PRESSURE REGULATOR BODY BEFORE YOU ATTEMPT THE CONVERSION. FAILURE TO FOLLOW ALL INSTRUCTIONS WILL RESULT IN A LEAK OR OVERFIRING OF THE APPLIANCE AND CAN LEAD TO AN EXPLOSION OR A FIRE HAZARD.

1. Remove the Courtesy Access Panel mounted behind the lower grill and lay down gently without disconnecting any wires of internal components. **WARNING: DO NOT FORCE. EXCESSIVE FORCE MAY DAMAGE INTERNAL WIRING COMPONENTS!**
2. Pull out and remove Extension Knob on NG Pressure Regulator and set aside.
3. Follow Instructions given below directly from SIT Controls. Replace Extension Knob as the final step.

WARNING!

The installation of this conversion kit must only be undertaken by a qualified and certified gas appliance installer.

HI/LO PRESSURE REGULATOR CONVERSION KIT INSTALLATION OR REPLACEMENT INSTRUCTIONS.

Verify that the following items are present in the package.

- Pressure regulator assembly (E)
- Two (2) screws (F)
- Identification label (G)
- Installation instructions (this document).

1 Shut off the gas supply to the valve and shut down the electric supply.

2 See Fig. 1. Using a Torx T20, or slotted screwdriver, remove and discard the two (2) pressure regulator mounting screws (A), pressure regulator tower (B), and the spring and diaphragm assembly (C).

3 Ensure the rubber gasket (D), which is prefitted as part of assembly (E), is properly positioned, see Fig. 2, otherwise fit the gasket as shown Fig. 2.

4 Install the new HI/LO pressure regulator assembly, as shown in Fig. 3 and Fig. 4. Use the supplied screws (F), M4 x 0.7 threaded, length of thread $L=(16\text{ mm} + 0 - 0.5\text{ mm})$, steel material, resistance class 8.8 (see Fig. 5).

5 Manually thread the two conversion kit mounting screws into the valve body. Use a standard screwdriver or T20 Torx bit and tighten to the screws with a fixing torque of $25\text{lb-in} \pm 5\%$.

IN THE EVENT THAT THE THREADS OF THE VALVE ARE STRIPPED OR DAMAGED, REPLACE THE VALVE.

6 Install the enclosed identification label (G) to the valve body where it can be easily seen.

7 Apply gas to system and re-light appliance according to manufacturers instructions.

8 With the main burner "ON", test the new pressure regulator assembly for leaks using a soap solution.

9 Relight the main burner in both the HI and LO positions, and verify proper burner ignition and operation.

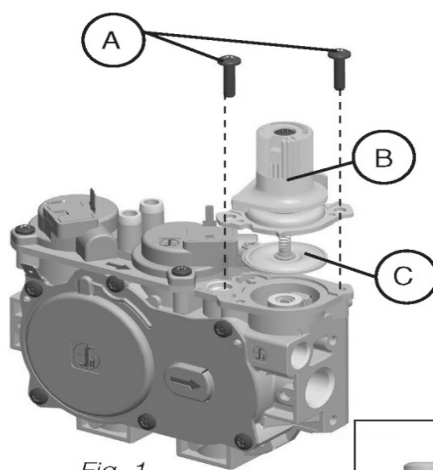

Fig. 1



Fig. 5

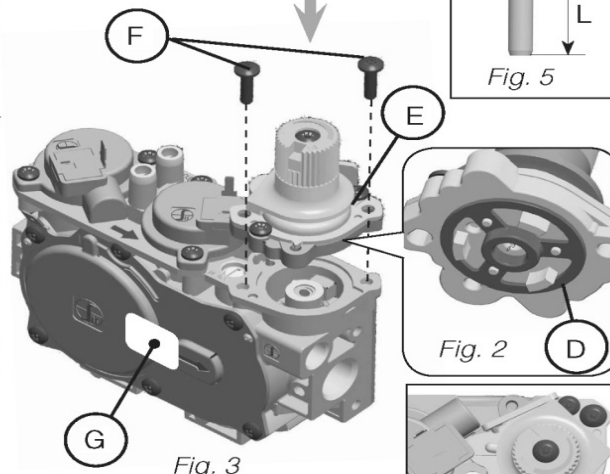

Fig. 3

Fig. 2

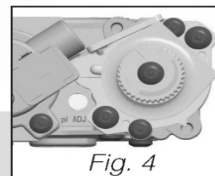

Fig. 4

WARNING!
Installation should be carried out in a clean environment.

WARNING!
This HI/LO conversion kit must ONLY be applied as part of a conversion kit supplied by the APPLIANCE MANUFACTURER for the specific appliance, and type of gas, being converted.

WARNING!
Correct operation of the system cannot be guaranteed if the conversion kit or valve has been dropped or has sustained a strong impact.

INSTALLER NOTICE. These instructions must be left with appliance.

LP GAS PRESSURE REQUIREMENTS

Inlet and manifold gas pressure checking taps are located on gas valve. These ports are only accessible from the outer left side of the fireplace. A qualified installer shall take pressure measurements at these ports to verify and set the correct gas pressures during the LP Kit installation and before fascia materials are installed over the front of this fireplace. Manifold pressure must be taken at the "MANIFOLD PRESSURE" tap and inlet pressure at the "INLET PRESSURE" tap **with the burner operating** by a qualified installer.

	DESIRED INLET PRESSURE	MINIMUM INLET PRESSURE	MAXIMUM INLET PRESSURE	MANIFOLD OUTLET PRESSURE	AIR SHUTTER POSITION
L.P. GAS	11.0" W.C. (2.75 kPa)	11" W.C. (2.75 kPa)	13.0" W.C. (3.24 kPa)	10.0" W.C. (2.5 kPa)	1/4" OPEN MIN. (5 mm)

REGULATE THE FLAME HEIGHT TO "HIGH" POSITION. OUTLET GAS PRESSURES MAY VARY PLUS OR MINUS 5%.

LPG PROPER INPUT RATES

With the proper orifices installed, as specified above, this fireplace utilizing LP Gas will have a maximum input rate of 31,000 Btu/Hr.

LEAK TESTING REQUIREMENTS

Prior to completing the conversion process, check for gas leaks with soap and water solution at all plumbing joints prior to placing this appliance into operation. It is recommended that all gas-plumbing joints, factory installed and field installed are checked for leaks.

PILOT FLAME AND MAIN BURNER RELATIONSHIP VERIFICATION

Prior to completing the conversion process, the qualified service technician must, **Figure 6: Pressure Test Port** light the pilot light and verify the relationship between the pilot light flames and the main burners. The pilot light flames directed towards the propagation ports on the rear and front burner must overlap the propagation ports on the burners. The pilot light flames must be a minimum of 3/4" long and must overlap the propagation ports on both the rear and front burners as shown in the diagram, below. Verify that the burner tubes ignite quickly and the burner flames propagate smoothly along the entire length of the burners.

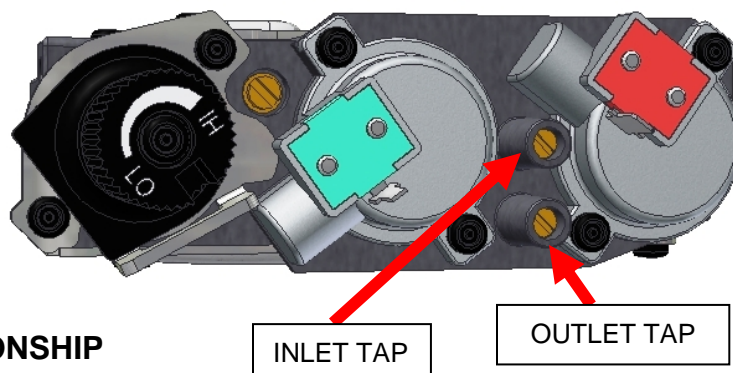

PILOT FLAME LENGTH ADJUSTMENT

If the pilot light flame length is too short and the system does not maintain a standing pilot, a qualified installer may increase the length of the pilot light flames to meet the two requirements: Minimum pilot light length to maintain a standing pilot light and the pilot light flames must be long enough to overlap the front and rear burner ports, 1 inch long minimum.

CHECKING FOR NORMAL BURNER(S) IGNITION CHARACTERISTICS

Once the conversion to LPG and all the above steps have been completed, light the main burners.

Turn Gas Dial counterclockwise to "ON" then set Thermostat or push Main Burner ON/OFF switch to turn on burners. Main burner should now light IMMEDIATELY and flame should not "lift" off burner. If there is any delay in ignition or if flame is "lifting off" burner, turn off burner and carefully check for proper installation of logs/coals, vent system and proper pilot flame impingement on burner and thermopile. Logs or coals must not block pilot flame or main burner flame. Vent system must be leak proof.

GAS LEAK TEST REQUIREMENT: It is the responsibility of the installer/service person to assure that each and every gas connection and supply tubing that are a part of this fireplace are leak proof. The qualified/ certified individual connecting the gas supply line, performing pressure tests or performing any service to this fireplace is required to perform a THOROUGH LEAK TEST on ALL gas fittings that are a part of this appliance or the gas supply line connection using soap-water solution or a calibrated combustible gas detector. Failure to perform this leak test may lead to a house fire and/or an explosion. Mendota is not responsible for any damages due to an Installer's failure to conduct a leak test and verify that all connections and supply lines are leak proof.

WARNING: Do not operate appliances with glass front removed, cracked, or broken. Replacement of glass should be done a licensed or qualified service person.

REPLACEMENT PARTS

MENDOTA DXV-45 DT3 FIREPLACE

PART NO	DESCRIPTION	PART NO	DESCRIPTION
65-02-00103	GLASS GASKET	05-04-00050	PILOT ASS'Y. NAT.
		05-04-00052	LP PILOT ORIFICE
65-06-00658	GLASS - FLAT		
HA-42-00210	DOOR FRAME ASS'Y. – FLAT	HA-42-00225	LP KIT
		65-14-00038	REAR ORIFICE (Nat. Gas) # 38
35-01-00320	LOG SET	65-14-00044	FRONT ORIFICE (NAT. Gas) # 44
		65-14-00053	REAR ORIFICE (LP Gas) # 53
35-01-00239	GLOWING INSWOOL	65-14-00364	FRONT ORIFICE (LP Gas) # 3/64
35-01-00302	FIREBRICK KIT		
35-01-00304	EMBER FLOOR SET		
10-03-00068	REAR FLAME WIRING W/ SWITCH	05-01-00157	SNAP-DISC (FAN TEMP SENSOR)
		10-01-00003	RHEOSTAT
HA-42-00200	VALVE ASSEMBLY WITH LP CONVERSION		
05-02-00364	VALVE NAT. GAS	15-02-00064	RIGHT HAND BLOWER - ONLY
HA-42-00011	MAIN BURNER TUBE WELDMENT	15-02-00065	LEFT HAND BLOWER - ONLY
70-01-00080	FRONT BURNER		

WARNING: Use only authorized parts and materials obtained from Johnson Gas Appliance when replacing any defective or damaged parts.

DO NOT substitute other manufacturer's materials or components.

DO NOT operate unit with cracked, broken or missing glass.

LISTING LABEL, RATING PLATE REPRESENTATION

**LISTED DIRECT VENT GAS FIREPLACE HEATER POËLE AU GAZ HOMOLOGUE', A
AÉRATION DIRECTE
NOT FOR USE WITH SOLID FUEL (NE DOIT PASÉ UTILISÉ AVEC UN COMBUSIBLE
SOLIDE)**

**Manufactured by (Fabriqué par): JOHNSON GAS APPLIANCE CO. CEDAR RAPIDS, IOWA
CERTIFIED FOR CANADA HOMOLOGUÉ POUR LE CANADA**

Tested to (Testé aux normes) ANSI Z21.88-2005 • CSA 2.33-2005 • CAN/CGA 2.17-M91 and ANSI Z21.50-1996.



WARNING: Improper installation, adjustment, alteration, service or maintenance can cause property damage, personal injury, or loss of life. Refer to the owner's information manual provided with this appliance. Installation and service must be performed by a qualified installer, service agency or the gas supplier. For use with glass doors certified with the appliance only. Do not operate with glass panel(s) removed, cracked, or broken. This vented gas fireplace heater is not for use with air filters. Register kit may be used.

MISE EN GARDE: Installation, réglage, modification, entretien ou dépannage non appropriés pourront causer des blessures ou des dommages matériels. Référez-vous au manuel du propriétaire fourni avec cet appareil. Pour assistance ou renseignements complémentaires, veuillez consulter un installateur expérimenté, une agence de dépannage/entretien ou votre compagnie gazière. Pour utilisation avec les portes en verre certifiée l'appareil seulement. Ne pas opérer avec le verre enlever, craquelure, brise.

	NATURAL GAS (Gaz Naturel)	PROPANE GAS (Gaz de pétrole liquéfié (GPL))
Input Rating (Btu/hr) 0 - 610 m (Entrée nominale)	45,000	40,000
Min. Input Rating (Btu/hr) 0 - 610 m (Minimale Entrée nominale)	6,500	5,000
Orifice 0 - 610 m (Orifice)	Front #44 Rear #38	Front 3/64" Rear #52
Orifice 610 - 1370 m (Orifice)	Front #45 Rear #38	Front 3/64" Rear #53
Maximum output (Btu/hr) (Sortie maximale)	32,400	28,800
Manifold Pressure (in w.c./kPa) (Pression au collecteur)	3.5/0.87	10.0/2.5
Manifold Pressure, low (in w.c./kPa) Pression d'entrée minimale)	1.7/0.42	3.6/0.90
Minimum Inlet Pressure (in w.c./kPa) (Pression d'entrée minimale)	5.0/1.25	11.0/2.75

This appliance is only for use with the type of gas indicated on the rating plate and may be installed in an aftermarket, permanently located manufactured (mobile) home where prohibited by local codes. See owner's manual for details. This appliance is not convertible for use with other gases, unless a certified kit is used.

Cet appareil sera installé conformément avec les codes locaux, le cas échéant. Si aucun code n'existe, suivez la norme ANSI Z223.1 ou la norme CAN/CGA (ACNOR)-B149.

MINIMUM CLEARANCES TO COMBUSTIBLE CONSTRUCTION

Unit to adjacent sidewall	10 in. (254mm)		
Unit to floor	0 in. (0mm)	Vent to enclosed top	3 in. (76.2mm)
Unit to enclosure sidewall	1 in. (25 mm)	Vent to enclosed side	14-3/4 in. (375mm)
Unit to enclosure back wall	1/2 in. (13mm)	Wall Pass-Through to framing	0 in. (0mm)
Unit top to ceiling	14-1/4 in. (374mm)	Mantle above discharge air opening	13 in. (330mm)

CAUTION: Hot while in operation. Do not touch. Keep children, clothing, furniture, and flammable liquids or vapors away. **ATTENTION:** L'appareil est chaud lorsqu'il fonctionne. Ne pas toucher l'appareil. Surveiller les enfants.

Garder les vêtements, les meubles, l'essence ou autres liquides à base de pétrole inflammables loin de l'appareil.

Electrical Rating (Courant nominal): 120 volts 60 hertz 1.5 amperes

**DO NOT REMOVE OR COVER THIS LABEL VEILLEZ À NE JAMAIS ENLEVER NI DISSIMULER CETTE ÉTIQUETTE
MODEL: DXV-45**

WH# _____

MENDOTA WARRANTY QUALIFICATION & SERVICE REFERENCE FORM

As a part of Mendota's on-going program of customer satisfaction, this Form verifies proper installation and operation. It is important as a reference for future service. It insures long life and trouble-free operation of Mendota fireplaces & stoves and qualifies the owner for Mendota's lifetime limited warranty. Owner should sign Form when completed and mail a copy along with Warranty Registration to Mendota. OPTIONALLY, PLEASE REGISTER AT OUR WEBSITE AT: WWW.JOHNSONGAS.COM/MENDOTA-REGISTRATION.ASP

HOME OWNER: _____ DEALER: _____
 ADDRESS: _____ ADDRESS: _____
 CITY/STATE/ZIP: _____ CITY/STATE/ZIP: _____
 SIGNATURE: _____ PHONE: _____
 MODEL #: DXV-45 _____ SERIAL #: _____
 DATE INSTALLED: _____

Mendota direct vent fireplaces are sophisticated, hi-tech gas appliances. All installation and operating instructions must be carefully followed. The DXV fireplace must be installed and serviced by a qualified Mendota approved service person.

REF: MENDOTA DXV45 DT3 INSTALLATION MANUAL

- APPROVED VENT PIPES AND VENT CAP INSTALLED - Per Manual.
 Vent pipes must be fully twist-locked and leak proof.
 Check minimum and maximum vertical / horizontal and vent runs.
- CHECK FOR PROPER CLEARANCES TO COMBUSTIBLES & VENT LOCATIONS - Per Manual
- INSTALL PROPER SIZE GAS LINES - CHECK FOR GAS LEAKS - Per Manual
- CHECK FOR CORRECT GAS PRESSURE AT MANIFOLD - Per Manual
 - a. 3.5 Inches Water Column Maximum - Nat. Gas (1/8" WC variation is allowed)
 - b. 10.0 Inches Water Column Maximum - L.P. Gas (1/8" WC variation is allowed)
- CYCLE BURNERS ON/OFF FOR PROMPT IGNITION - Per "LIGHTING INSTRUCTIONS"
 Burner must light IMMEDIATELY - Flame must travel promptly around "curve" & light burner.
- INSTALL LOGS AND ADJUST FLAME - Per Manual
 Proper pilot flame impingement on flame sensor & burner - Air shutter opening: 1/16" - 1/8" Nat. Gas - 1/4" LP
 Check that flame is "stable" and is not "lifting" off burner
- BRIEF OWNER ON OPERATION AND MAINTENANCE OF UNIT

Light Pilot	Operate Burner	Explain blower "delay" operation
-------------	----------------	----------------------------------

WARRANTY REGISTRATION		
Your Name _____		
Address _____		
City _____	State _____	Zip _____
Dealer (Place of Purchase) _____		
City _____	State _____	Zip _____
Date of Purchase _____	Serial Number _____	
Purchaser's Signature _____		

MENDOTA DXV-45DT3 DIRECT VENT FIREPLACE

CUT OUT PAGE AND MAIL TO: JOHNSON GAS APPLIANCE CO., 520 E AVE. N.W., CEDAR RAPIDS, IOWA 52405
PLEASE REGISTER AT OUR WEBSITE AT: WWW.JOHNSONGAS.COM/MENDOTA-REGISTRATION.ASP

TAPE SHUT



**JOHNSON GAS APPLIANCE COMPANY
520 E AVENUE N.W.
CEDAR RAPIDS, IA 52405**

MENDOTA EXTENDED LIFETIME PROTECTION AND LIMITED WARRANTY

MENDOTA DXV45 DT3 DIRECT VENT FIREPLACE

Mendota Division of Johnson Gas Appliance Company, 520 E Avenue N.W. Cedar Rapids, Iowa 52405, extends this Extended Lifetime Protection and Limited Warranty to the original purchaser of a Mendota DXV Fireplace, Serial Number, which is limited and used under normal home conditions.

STANDARD WARRANTY:

JOHNSON GAS APPLIANCE CO., MENDOTA DIVISION, WARRANTS THAT YOUR NEW MENDOTA FIREPLACE IS FREE FROM MANUFACTURING AND MATERIAL DEFECTS FOR A PERIOD OF ONE YEAR FROM THE DATE OF INSTALLATION, SUBJECT TO THE FOLLOWING CONDITIONS AND LIMITATIONS:

EXTENDED LIFETIME WARRANTY:

THE HEAT EXCHANGER, BURNER TUBE COMBUSTION CHAMBER AND OUTER SHELL OF THIS MENDOTA FIREPLACE ARE WARRANTED FOR THE LIFETIME OF THE ORIGINAL OWNER, SUBJECT TO PROOF OF PURCHASE AND THE FOLLOWING CONDITIONS AND LIMITATIONS:

1. This new Mendota Fireplace must be installed & serviced by a competent, authorized service contractor. It must be installed and operated at all times in accordance with the installation and operating instructions furnished with the Fireplace. All adjustments to logs. Coals or burner must be made by an authorized Mendota person. Any alteration, willful abuse, accident or misuse of the product shall nullify this warranty. This warranty does not cover glass or log breakage.
2. This limited warranty does not cover the cost of service calls, the cost of labor to remove or install parts covered by this limited warranty, freight or other transportation expenses, which may be incurred in connection with obtaining performances under this limited warranty. The remedy for damages as the result of any defects in this product which have been warranted herein is limited to replacement parts and does not include any incidental, indirect or consequential damages or expenses sustained in connection with the product, including damages to property, except as provided by law.
3. This warranty is non-transferable and is made to the original retail purchaser, provided the purchase was made through an Authorized Mendota Dealer.
4. Mendota is not responsible for any damage to or malfunction of the Fireplace unless caused by a defect in material or workmanship from normal home use. Damage caused by abuse, improper installation, improper servicing, and installation by unqualified personnel or breach of conditions of this limited warranty will excuse Mendota from performance of any part of this limited warranty. Mendota has the right to investigate and inspect the exact, original Fireplace and entire installation (without any alterations or tampering) in the event a claim is made to determine whether the claimed damage or malfunction was caused by abuse, improper installation or other cause outside this warranty. Mendota is not responsible for any repairs or material purchases that have not received prior written approval from Mendota.

NOTE: Minor warping of certain parts or discoloration is normal and is not a defect covered by this warranty. Major warping of parts can be caused by over-firing of your Mendota Fireplace. Over-firing above rated nameplate specification is as contrary to the manufacturer's instructions and may void this warranty.

5. This warranty may not be extended by our representatives or any third party in any manner. The company neither assumes, nor authorizes any third party to assume, on its behalf, any other liabilities with respect to the sale of this Mendota product.
6. Mendota may at its discretion, fully discharge all obligations of this warranty by refunding the wholesale price of the defective part(s).
7. All other warranties - expressed or implied - with respect to the product, its components and accessories, or any obligation/liabilities on the part of the company are hereby expressly excluded. Products made by other manufacturers, sold with the Fireplace or thereafter, are not covered by this limited warranty. The use of unauthorized components will make this warranty null and void.
4. This warranty shall be effective only if the original purchaser of the Mendota appliance is registered with Mendota Division within thirty (30) days of the date of purchase. Such registration or the failure to register shall not be deemed to create any obligation or liability by the manufacturer and this warranty with its conditions and limitations shall be the only procedure for obtaining any rights against the manufacturer and expresses the sole obligation and responsibilities of the manufacturer which are offered to the original purchaser and accepted upon purchase of the appliance.
5. Mendota Division, reserves the right to make changes at any time without notice, in design, material, specifications, prices and the right to discontinue styles and products.
6. Some states do not allow the exclusion of limitation of incidental or consequential damages or limitations on how long an implied warranty lasts, so the above limitation or exclusion may not apply to you. This warranty gives you specific legal rights and you may also have other rights which vary from state to state.

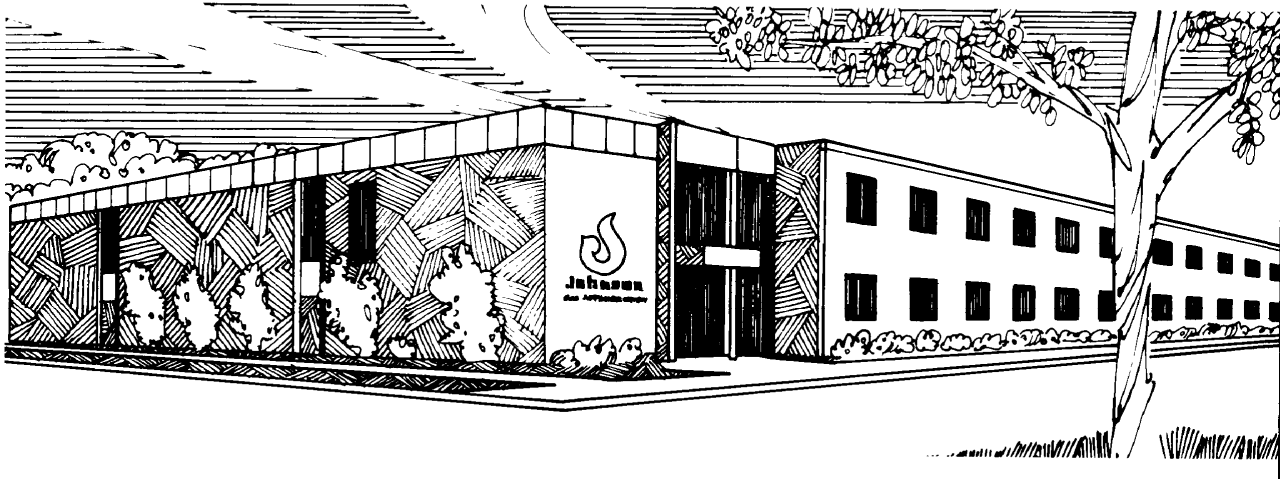

Johnson Gas Appliance Company
520 E Avenue N.W. - Cedar Rapids, IA 52405
Mendota Hearth Division
www.johnsongas.com or www.mendotahearth.com